

Original scientific paper

UDC: 519.673:622.24

DOI: 10.7251/afts.2015.0712.045N

COBISS. RS-ID 4988440

PORE PRESSURE AND FRACTURING PRESSURE INFLUENCE AT BOREHOLES CONSTRUCTION ON THE ROCK SALT DEPOSIT "TETIMA" TUZLA

Nuhanović Sanel¹, Hodžić Adnan¹, Šabović Almir²

¹ Faculty of Mining, Geology and Civil Engineering, Tuzla. E.mail: sanel.nuhanovic@untz.ba

² Mining Institute, Tuzla

SUMMARY

In the rock salt deposit "Tetima" by analysis of situation and pore (layers) pressures and fracturing pressures development it has been proved that the values of pore and fracturing pressures are quite low (in the part of deposit which is currently exploited) and on the border of use salt water such as fluid for canal rinse in some drilling intervals. That especially relates to the "weak" breccia layer, stationed just above rock salt series, which is rated as most likely zone of drilling fluid loss and hermeticity loss of all constructed boreholes in that part of deposit. Calculated values of pore pressures, fracturing pressures and their gradients indicate on need for correction of existing boreholes construction on the rock salt deposit "Tetima". Analysis results of six constructed boreholes are presented in this paper, by analytical and graphical method.

Key words: *borehole, construction, pore pressure, fracturing pressure*

INTRODUCTION

Rock salt deposit "Tetima" is characterized by a complex geological structure. In the lithological column there are several zones which can be characterized as „weak“ or potentially hazardous to the requested maximal borehole hermetic nature, especially if is planned multipurpose usage of borehole. Analysis of situations and formation's pore and fracturing pressures development, such as their gradients in the borehole's profile present starting point for the borehole design. Reduced values of pore pressures open possibility of drilling fluid loss somewhere in the borehole canal as a result of potential equalization (differential pressure). The same conclusion could be transferred to the determined values of fractured gradients or fracturing pressures which occur in the constructed boreholes profile (in the observed part of deposit).

Consequently, analysis of the situation and development of pore pressures and fracturing pressures of layers in the rock salt rock deposit "Tetima" has a special importance. Only in this way can be defined quality parameters to build a hermetic and long lasting boreholes which except for the exploitation of salt water can be used for the purpose of various materials and energy storage, what will significantly extend their "lifetime".

PORE PRESSURE AND FRACTURING PRESSURE CALCULATION RESULTS

Pore pressure values for every each of 6 analyzed boreholes (B-86, B-97, B-78, B-92, B-87 i B-77) are determined by standard equation [1], by which it can be obtained orienting value of pore pressure at a certain depth:

$$p_{sl} = \frac{H \cdot \gamma_i}{10} \cdot 0,981 \text{ [bar]}$$

where is:

H – arbitrarily selected interesting depth, [m]

γ_i – drilling fluid or other fluid density in borehole canal, [kg/m³]

Wherein, as especially interesting depths, are taken borders marl-breccia in the rock salt top, then border breccia-rock salt, and border with rock salt body underlayer. To determine prognostic values of fracturing pressure and fracturing gradient there are used 3 indirect methods that are commonly mentioned in the literature [2], namely:

- method Hubbert – Willis
- method Matthews – Kelly
- method Ben Eaton

Calculation results are given separately for each of 6 analyzed boreholes [3], and here we present results obtained for the borehole B-86, table 1.

Table 1. Values of pore pressure, fracturing pressure and fracturing gradient on the borehole B-86, rock salt deposit „Tetima“

TETIMA: borehole B – 86							
H (m)	P _{sl} (bar)	Fracturing pressure "P _F " (bar)			Fracturing gradient "G _f " (bar/m)		
		Hubbert-Willis	Matthews-Kelly	Ben Eaton	Hubbert-Willis	Matthews-Kelly	Ben Eaton
150,00	16,19	22,10	23,63	22,41	0,147	0,157	0,149
200,00	21,58	29,46	31,38	30,10	0,147	0,157	0,150
250,00	26,98	36,82	40,26	38,75	0,147	0,161	0,155
300,00	32,37	44,18	49,02	47,55	0,147	0,163	0,159
436,00	47,05	64,22	73,31	70,18	0,148	0,168	0,161
448,40	52,78	68,97	77,55	75,12	0,154	0,173	0,167
542,80	63,92	83,50	94,47	92,20	0,154	0,174	0,170

Taking the method of Ben Eaton-a as the most accurate (in drilling practice the most applied method), using data from table 1, it can be constructed diagram of gradient of formation pressure and fracture gradient changes, in the function of borehole depth.

That diagram can be used for borehole's tubing depth determination, where we can get one "alternative" borehole B-86 construction, derived based on available data of pore pressures and fracturing pressures conditions in the narrow borehole zone.

RESULTS APPLICATION

Values obtained by calculation we use for graphical determination of individual casing depth installations [4]. In this paper we will mention two ways of graphics provisions of casing depth installation depth, where the first method is commonly used for deeper exploration oil and gas boreholes, while the second method is commonly used in the selection of casing depth of shallow boreholes (although it is not standard, so that the second method is often used in the oil industry).

THE FIRST GRAPHICAL METHOD

On the diagram we apply value of pore pressure gradient, line of drilling fluid gradient (gradient of pore pressure increased with safety factor or with value which ensures smooth extraction of tool from borehole – usually that value is 0,03 – 0,05 bar/10 m, or on the bottom of borehole affect pressure which is about 10 – 30 bar higher than formation pressure), line of fracturing gradient in a function of depth, and line which is obtained when we value of fracturing gradient decrease for value of safety factor or value which ensures borehole attenuation without the risk of rock layers breakage, or for the value that prevents the underground blowout (that value depends of quantity and type of formation fluid which flows into the borehole canal, as well as of chosen method of borehole attenuation);

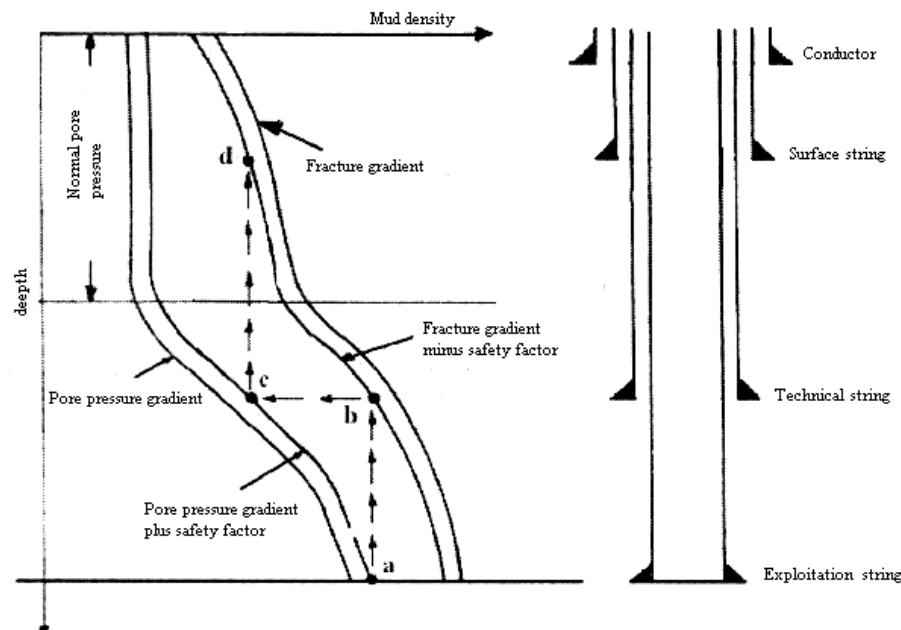

Figure 1. Preview of the first graphical method for borehole construction determination

If we apply this to the borehole B-86, with results obtained and presented in table 1, we obtain construction shown in Figure 2, which clearly shows that offered borehole design, obtained in this way, differs from built borehole B-86 construction [5,6,7,8].

Construction allows building of borehole without surface tubing which is necessary for installation of surface equipment. Conclusion is that the surface protective tubing can be installed to an arbitrary depth covering like that shallow aquifer, with obligatory to its cementing to the top.

This look of diagram says that drilling fluid program is correct and that the same drilling fluid density (about 1100 - 1200 kg/m³) matches to the borehole construction along the whole its canal from the surface to the final depth, by using salt water as drilling fluid in the intervals through the rock salt formation.

THE SECOND GRAPHICAL METHOD

With this method of diagram determining borehole construction, casing depth installation is based on an expected maximal formation pressure in conditions when the borehole is completely filled with formation fluid. The method is particularly useful in the case of the construction of smaller and mid-depth boreholes (1000 m), especially in areas where tectonic activity is not expressed to a significant extent, although it is also used in the design of deeper exploration-exploitation boreholes.

This method of diagram borehole construction determination implies that the density of produced fluid and fracturing gradient of formation have constant values, where formation fracturing gradient is equal with geostatic gradient or overburden.

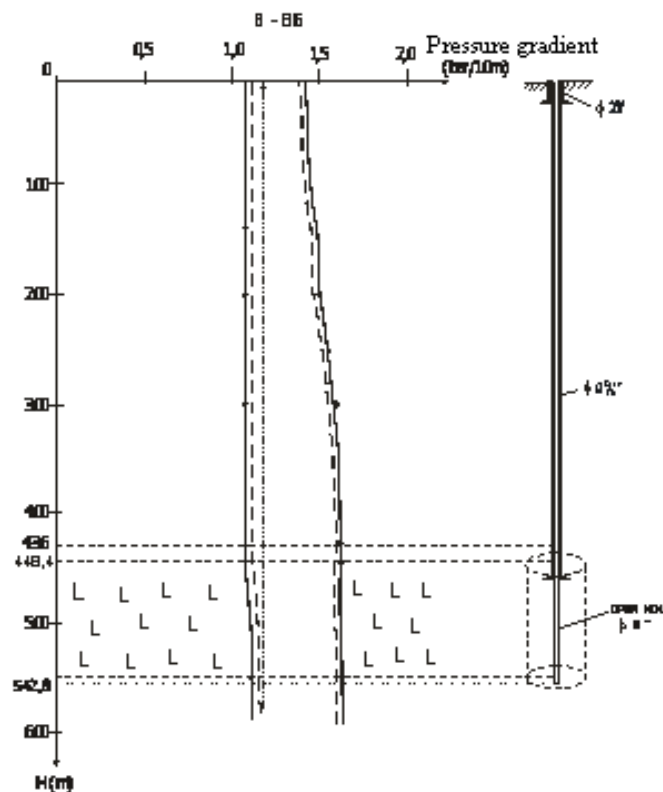

Figure 2. Construction of borehole B-86, on the rock salt deposit "Tetima", obtained by the first graphical method

According to this method, due to the data presented in Table 1, the construction of borehole B-86 would look like as in Figure 3. This method gives us a a little different picture of borehole construction, a more realistic compared to the actual conditions that prevail in the deposit. Formation pressure value at the final borehole depth of 549,80 m is 65,26 bar, what gives formation pressere gradient of 0,119 bar/m.

Pressure of drilling fluid must be higher than formation pressure, so we at obtained value 7-20 bara (since it is a borehole with depth around 600 m, it is enough to add 9-10 bar). In this way we get the value of drilling fluid pressure (on the borehole bottom) of 75,26 bar, what gives drillin fluid gradiant of 0,135 bar/m. Formation fracturing gradijent value (gradifent of overlaying rocks pressure) is 0,226 bar/m, what is common value which is in literature used for normally consolidated formations (marls, clays, rock salts..), and for depth 549,80 m gives fracturing pressure of 124,20 bar.

Taking into account depth of the last installed casing (techical casing Φ 244,50 mm), which enters into rock salt formatio and whose foot is 20,00 m bellow rock salt overlayer (depth of 468,50 m), we calculate value of formation pressure on that depth and it is 52,78 bar.

Obtained value is decreased for value of gas attenuation (we obtain it when depth multiply with 0,009, what in this case is 4,2 bar), what gives value of formation pressure 48,58 bar (broken line at diagram). The point in which constructed line of formation pressure intersects line of formation fracture gradient, gives us the value of surface tubing installation depth.

It should be noted that the depth (in this case $H = 225$ m) is taken as an orientig because this way of its determination generally receive a little higher depth values, which can be reduced for about 50 meters (depending of conditions in the borehole). Since is here taken as the basis technical casing depth

calculation and not designed borehole depth, mentioned defect of this method can be considered as reduced, and obtained surface tubing installation depth more precise and realistic.

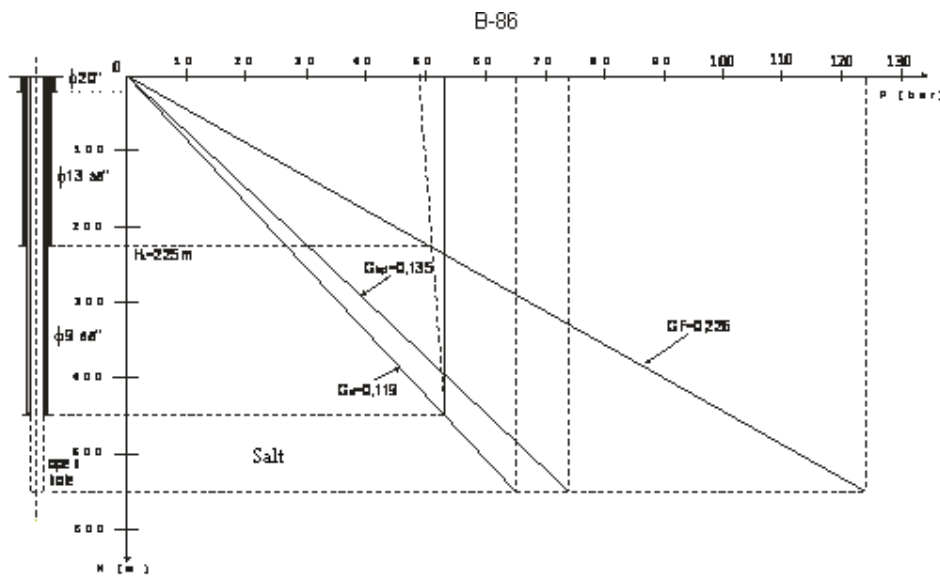

Figure 3. Diagram of pressures with adequate borehole B-86 construction, on the rock salt deposit „Tetima“, obtained by the second graphic method

It should be noted that the precise depth of surface tubing depends on the lithological borehole profile, because casing foot must be located in impermeable formations.

BOREHOLE B-86 CONSTRUCTION BASED ON ANALYSIS OF PORE PRESSURE AND FRACTURING PRESSURE INFLUENCE

Average depth for surface casing installation on the example of borehole B-86 is approximately 225,00 m. Borehole construction obtained by presented graphical method is shown in Figure 4.

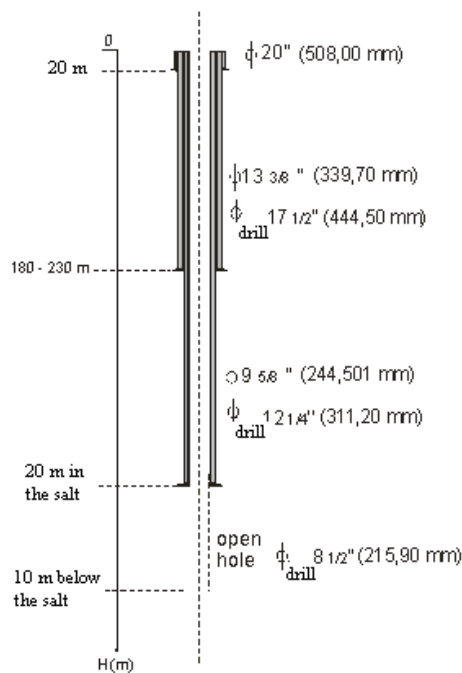

Figure 4. Construction of multifunctional borehole on the rock salt deposit „Tetima“

As already mentioned, this graphical method allows correction of obtained casing depth installation, so that the resulting depth can be reduced to a maximum of 50 m. Analyzing the lithological column and knowing the hydrogeological characteristics of the rock salt deposit "Tetima", in constructions of multifunctional boreholes should be taken into account piping of first water-bearing horizon with surface tubing. That waterbearing horizon is represented by inter layers of silicified limestone in the Sarmatian and Upper Tortonian sandstones, which boundarie in this deposit is at about 160-180 m of depth.

Thus, the depth of surface casing installation certainly should not be less than 180.00 m, or need to be in the obtained depth interval from 230.00 to 180.00 m.

CONCLUSION

According to the results obtained by calculations of the situation and development of pore and fracture pressures on six exploration-exploitation boreholes (this paper gives an example of borehole B-86) it is presented the "alternative" construction of borehole B-86, which with the proper technology construction could and should provide the necessary hermetic nature as a precondition for possible multifunctional usage of boreholes that will be constructed in the future.

Calculated results were used as starting point for borehole construction by graphical method (the second method), where is obtained installation depth for particular casings is given with diameters of installed safety casings and drilling diameters which do not change compared to already established practice. Offered construction differs from so far constructed boreholes in the depth of surface casing interval between 180-230 m.

Surface tubing installation depth (or the first technical tubing, how is mentioned in borehole construction reports), at till now built boreholes in area of rock salt deposit varies from 77,50 m, (for borehole B-97) to 184,00 m (for borehole B-77). Considering the hydrogeological characteristics of the deposit, within which it is stated that the first aquifer was determined in the sediments of Upper Tortonian / Pannonian and Sarmatian with total thickness of approximately 200.00 m, it should be invited to the proven practice of borehole construction designing which states that the casing foot should be located in stable formations isolating the water-bearing layers above.

Respecting this rule, depth of surface casing installation obtained by above mentioned graphical method (average depth is 225.00 m) is quite correct. Installation depth of technical casing is determined by the depth of a salt body, so that its determination was not the subject matter.

(Received February 2015, accepted February 2015)

REFERENCES

- [1] Bizjak, R. (2004). Drilling technology with designing. Novi Sad. DIT NIS-Naftagas Novi Sad.
- [2] Bizjak, R. (1997). Controle of borehole fluids inflow. Novi Sad. DIT NIS-Naftagas Novi Sad.
- [3] Nuhanovic, S. (2010). Multifunctional boreholes construction on rock salt deposit. Tuzla. rudarsko-geološko-građevinski fakultet - disertation.
- [4] Borzatti, J., Borić, D., Mikuš, B., Pavic, V. (1989). Contribution to borehole piping methodology. Zagreb. INA-NAFTAPLIN Zagreb.
- [5] Supplemental mining project of boreholes B-86 i B-97 sanation, on the rock salt mine «Tetima», with aim of continued exploitation. Tuzla. Team for investigations nad explorations of rock salt. Mining institut Tuzla, 2002.
- [6] Nuhanovic, S. (2006). Pore pressure influence at the bulidings technology of exploration-exploitation wells on the salt pit "Tetima" in Tuzla. Tuzla. Rudarsko-geološko-građevinski fakultet.
- [7] Hadzihrustic, Z. (2006.). Exploration drilling I. Tuzla. University of Tuzla.
- [8] Technical design of the drilling and installation of exploitation wells in rock salt deposit „Tetima“ from the surface. Tuzla. Geotehnika Zageb, 2008.