

Preliminary report
UDC: 624.011.1.074.2
DOI: 10.7251/afts.2013.0508.043B

ANALYSIS OF SNAP BEHAVIOUR OF SHALLOW CYLINDRICAL SHELLS USING THE FINITE STRIP METHOD

Borković Aleksandar¹

¹Univerzitet u Banjaluci, Arhitektonsko-građevinsko-geodetski fakultet, E.mail: aborkovic@agfbl.org

ABSTRACT

This paper presents one approach for the analysis of snap behaviour of simply supported elastic shallow shells. Structure is discretized with the finite strip method. Displacement field is approximated with series of products of polynomials and harmonic functions. Only geometric nonlinearity of von Karman type is considered. Equilibrium equations are derived via principle of stationary value of total potential energy and solved with arc-length method. Total Lagrangian approach is used. Detailed analysis of one shallow shell is performed. Obtained results are in good correspondence with the ones from the finite element method.

Key words: *shallow shells, finite strip method*

INTRODUCTION

Cylindrical shells are very popular in contemporary civil engineering. Due to their favourable stiffness/weight ratio, they are almost irreplaceable for long spans. These structures are characterized with regular geometry, i.e. they have arbitrary cross section which runs constantly in longitudinal direction. Special class of these constructions are shallow shells, whose specific behaviour is subject of many present-day researches. In fact, elastic shallow shells subjected to vertical loading follow complex equilibrium paths which may include snap-through and snap-back behaviour. Snap-through is observed when structure reaches load limit point, and snap-back when the structure reaches displacement limit point. Although not common in practice, this behaviour is experimentally proved [1].

Behaviour of mechanical systems is described with partial differential equations which have closed form solutions for just few simple cases. This is the reason why the approximative solution is looked for. Domain is usually discretized, and nonlinear system of algebraic equations is obtained. This system is commonly solved with incremental-iterative procedures, such as Newton-Raphson method, where the load or displacement control is applied. Unfortunately, these procedures cannot describe both kind of snap behaviour. On the other hand, arc-length method can describe both load and displacement limit points [1].

Finite strip method (FSM) is suitable for analysis of 'long' structures because of adopted discretization of continuum. It proves more efficient than finite element method (FEM) for the analysis of certain classes of structures [2,3]. While FEM uses polynomials for discretization of plane structures in both

directions, FSM uses fast converging trigonometric functions for approximation in longitudinal direction. It follows that FSM is semi-analytical procedure, unlike the FEM which is purely numerical. Geometric nonlinear analysis of structures using the FSM is occupying researchers for many years. Nonlinear behaviour of rectangular plates is analysed in [4, 5]. However, for structures with more complex geometry, authors commonly use spline functions [6]. According to available literature, this is the first paper which deals with snap behaviour of shells using the harmonic functions. Shells are modelled with plane finite strips which are derived according to Kirchhoff's presumption for the bending of the thin plates where the displacement field of the plate is described as the function of the displacements of the middle plane

Adopted finite strip and assumed displacement field are briefly presented. Derivation of nonlinear equations of equilibrium and arc-length method are described concisely. At the end, detailed numerical example of one shallow shell is given with comparison of the FSM/FEM results.

FINITE STRIP INTERPOLATING FUNCTIONS

Finite strip of flat shell with eight degrees of freedom is given in Figure 1. Unlike the finite elements, degrees of freedom of finite strip are displacement parameters in nodal lines.

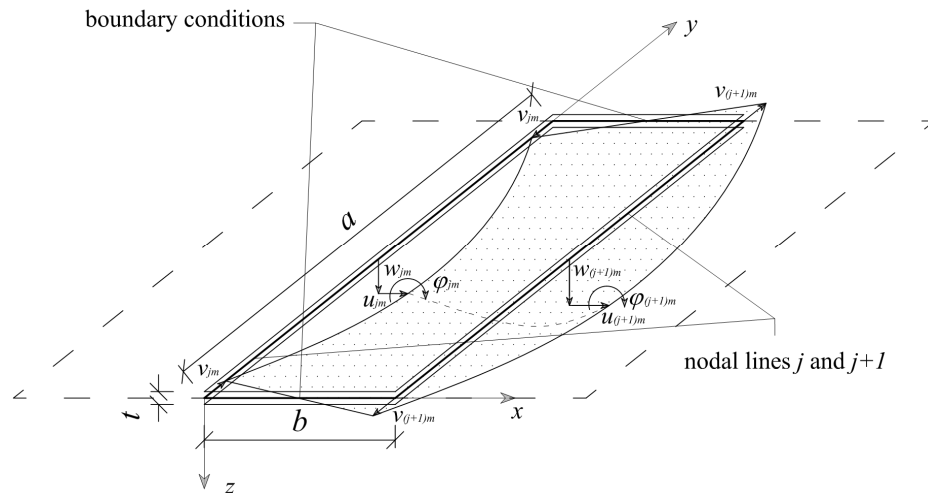

Figure 1 Finite strip interpolating function and displacement parameters for $m=1$

Displacement components are approximated with series of products of polynomials and trigonometric functions

$$u_0(x, y) = \sum_{m=1}^{nst} u_{0m}(x)Y_m(y) \quad v_0(x, y) = \sum_{m=1}^{nst} v_{0m}(x)Y_m^v(y) \quad w(x, y) = \sum_{m=1}^{nst} w_m(x)Y_m(y). \quad (1)$$

where nst is the number of series terms considered in analysis. Trigonometric functions are chosen as the free vibration eigenfunctions of Bernoulli-Euler beam which are $Y_m = \sin(m\pi y/a)$ for simply supported boundary conditions. Because of their nature, these functions are especially efficient for dynamical analysis of structures [7]. In order to satisfy boundary conditions $v(0) \neq 0$ and $v(a) \neq 0$, functions Y_m^v are usually taken as $\cos(m\pi y/a)$. Wang and Dawe [4] shown that this function cannot adequately represent absolutely free displacement in y direction when nonlinear effects are considered. They proposed other functions which are used here:

$$Y_1^v = a/2 - y \quad Y_m^v = \sin[(m-1)\pi y/a], \quad m = 2, 3, \dots, nst. \quad (2)$$

This kind of boundary conditions describes supporting on diaphragms. End cross sections have restrained displacements in its own plane and absolutely free out of it. Strip displacement in transverse direction is approximated with polynomials which are linear for in-plane and cubic for out-of-plane displacement components

$$\begin{aligned} u_{0m}(x) &= (1-\xi)u_{jm} + \xi u_{(j+1)m} = \mathbf{N}_u^T \mathbf{q}_{um}^u & \xi &= x/b \\ v_{0m}(x) &= (1-\xi)v_{jm} + \xi v_{(j+1)m} = \mathbf{N}_u^T \mathbf{q}_{um}^v \\ w_m(x) &= (1-3\xi^2 + 2\xi^3)w_{jm} + (x-2b\xi^2 + b\xi^3)\varphi_{jm} \\ &+ (3\xi^2 + 2\xi^3)w_{(j+1)m} + (-b\xi^2 + b\xi^3)\varphi_{(j+1)m} = \mathbf{N}_w^T \mathbf{q}_{wm} \end{aligned} \quad (3)$$

EQUILIBRIUM EQUATIONS

Following Kirchhoff's theory, thin plate has only three strain components

$$\boldsymbol{\varepsilon} = \begin{bmatrix} \varepsilon_x \\ \varepsilon_y \\ \varepsilon_{xy} \end{bmatrix} = \begin{bmatrix} u_{0,x} - z w_{,xx} \\ v_{0,y} - z w_{,yy} \\ u_{0,y} + v_{0,x} - 2z w_{,xy} \end{bmatrix} + \begin{bmatrix} (1/2)(u_{0,x}^2 + v_{0,x}^2 + w_{,x}^2) \\ (1/2)(u_{0,y}^2 + v_{0,y}^2 + w_{,y}^2) \\ (u_{0,x}u_{0,y} + v_{0,x}v_{0,y} + w_{,x}w_{,y}) \end{bmatrix} = \boldsymbol{\varepsilon}_L + \boldsymbol{\varepsilon}_{NL} \quad (4)$$

which can be decomposed into linear and nonlinear in displacement gradients. Strain vector can also be decomposed into membrane and bending part

$$\begin{bmatrix} \varepsilon_x \\ \varepsilon_y \\ \varepsilon_{xy} \end{bmatrix} = \begin{bmatrix} \varepsilon_{x0} \\ \varepsilon_{y0} \\ \varepsilon_{xy0} \end{bmatrix} - z \begin{bmatrix} \kappa_x \\ \kappa_y \\ 2\kappa_{xy} \end{bmatrix} = \begin{bmatrix} u_{0,x} + (1/2)(u_{0,x}^2 + v_{0,x}^2 + w_{,x}^2) \\ v_{0,y} + (1/2)(u_{0,y}^2 + v_{0,y}^2 + w_{,y}^2) \\ u_{0,y} + v_{0,x} + (u_{0,x}u_{0,y} + v_{0,x}v_{0,y} + w_{,x}w_{,y}) \end{bmatrix} - z \begin{bmatrix} w_{,xx} \\ w_{,yy} \\ 2w_{,xy} \end{bmatrix} \quad (5)$$

where it is observed that nonlinear members influence only membrane strain, while the curvatures remain the same as in linear analysis. This paper considers only addends which are nonlinear in deflection gradient which matches von Karman theory [3].

Total potential energy of elastic system is equal to sum of work of external forces and strain energy $\Pi = W + U$. Strain energy is defined as integral of product of stress vector and strain vector over the volume of the body

$$U = \frac{1}{2} \int_V \boldsymbol{\varepsilon}^T \boldsymbol{\sigma} dV = \frac{1}{2} \int_V \boldsymbol{\varepsilon}^T \mathbf{D} \boldsymbol{\varepsilon} dV \quad (6)$$

In Eq. (6) vectors $\boldsymbol{\sigma}$ and $\boldsymbol{\varepsilon}$ consist of components of second Piola-Kirchhoff stress tensor and Green-Lagrange strain tensor, respectively. \mathbf{D} is constitutive matrix, derived according to generalized Hooke's law. All quantities are measured in reference to undeformed configuration which means that the total Lagrangian approach is used. For a system in equilibrium, gradient of total potential energy must have stationary value. In fact, it proves that this value is minimal. Applying this principle, equilibrium equations are obtained

$$\delta \Pi = \frac{\partial \Pi}{\partial \mathbf{q}} \delta \mathbf{q} = 0 \quad \delta \mathbf{q} \neq 0 \Rightarrow \frac{\partial \Pi}{\partial \mathbf{q}} = \boldsymbol{\Psi}(\mathbf{q}) = \mathbf{R}(\mathbf{q}) - \mathbf{F} = 0. \quad (7)$$

Expression (7) represents system of nonlinear equations where $\boldsymbol{\Psi}$ is the vector of residual (unbalanced) forces; \mathbf{R} is the vector of internal nodal forces; \mathbf{F} is the vector of externally applied load, here

presupposed independent of displacement. This system is usually solved using the successive linearization by Taylor series expansion where gradient of Ψ should be found

$$\frac{\partial \Psi}{\partial \mathbf{q}} = \mathbf{K}_T \tag{8}$$

result of which is well-known tangent stiffness matrix.

SOLVING EQUATIONS

In order to follow complex equilibrium paths which consist of snap-through and snap-back behaviour, linearised arc-length method is used for solution of equilibrium equations [1]. This method introduces load proportionality factor λ as the new variable

$$\Psi(\mathbf{q}, \lambda) = \mathbf{R}(\mathbf{q}, \lambda) - \lambda \mathbf{F} = 0. \tag{9}$$

Because of a new unknown variable, new constraint equation is necessary. According to simplified linearised arch-length approach, constraint equation is

$$\Delta \mathbf{q}_p^T \delta \mathbf{q} = \Delta \mathbf{q}_p^T (\delta \bar{\mathbf{q}} + \delta \lambda \delta \mathbf{q}_t) = 0 \tag{10}$$

and the iterative load factor $\delta \lambda$ is calculated as

$$\delta \lambda = \frac{-\Delta \mathbf{q}_p^T \delta \bar{\mathbf{q}}}{\Delta \mathbf{q}_p^T \delta \mathbf{q}_t} \tag{11}$$

where $\Delta \mathbf{q}_p$ is incremental predictor displacement vector, $\delta \mathbf{q}_t$ is vector of tangential displacements and $\delta \mathbf{q}$ is iterative residual displacement vector

$$\delta \bar{\mathbf{q}} = -\mathbf{K}_T^{-1} \Psi \quad \delta \mathbf{q}_t = \mathbf{K}_T^{-1} \mathbf{F}. \tag{12}$$

After the new load factor is calculated, updated displacements are obtained and equation (9) checked. Because of numerical nature of procedure, equilibrium will never be satisfied and appropriate convergence criterion must be employed. Here it is introduced via ratio of Euclidian norms of the vector of unbalanced forces and the vector of current external load

$$\|\Psi\| / \|\lambda \mathbf{F}\| \leq \alpha, \tag{13}$$

where α is some prescribed value, usually between 10^{-2} and 10^{-3} , depending on the problem considered and desired accuracy. Presented solution procedure is based on predictor-corrector technique where arc-length method iterations act as correctors while predictor solution is determined from

$$\Delta \lambda_p = \pm \frac{\Delta l}{\sqrt{\delta \mathbf{q}_t^T \delta \mathbf{q}_t}} \tag{14}$$

where Δl is the given incremental arc-length. Problem of choosing sign in Eq. (14) is heavily addressed in literature and sign of the minimum eigenvalue of tangent stiffness matrix is recommended as the most accurate [1, 6]. In this research it is found that this criterion can lead to wrong solution, and the sign of current stiffness parameter is used instead.

NUMERICAL EXAMPLE AND DISCUSSION

Presented procedure is programmed into software package Wolfram Mathematica by upgrading the program presented in [7], and the result is code named NOLA (nonlinear analysis). This program is now able to conduct geometric nonlinear analysis of many engineering structures such as: rectangular plates, thin-walled beams, cylindrical shells etc.

In order to validate the presented method, detailed numerical analysis of the shell given in Figure 2 is performed. Shell is discretized with finite strips and finite elements. Using the conditions of symmetry, only half of the shell is modelled. Results obtained with NOLA are given for two discretizations, designated as D1 and D2. D1 model is discretized with 12 strips and 7 series terms, while the model D2 has 36 strips and 15 series terms. Since every nodal line has 4 degrees of freedom, it follows that model D1 has 364 ($13 \times 4 \times 7$), and model D2 2220 ($37 \times 4 \times 15$) degrees of freedom.

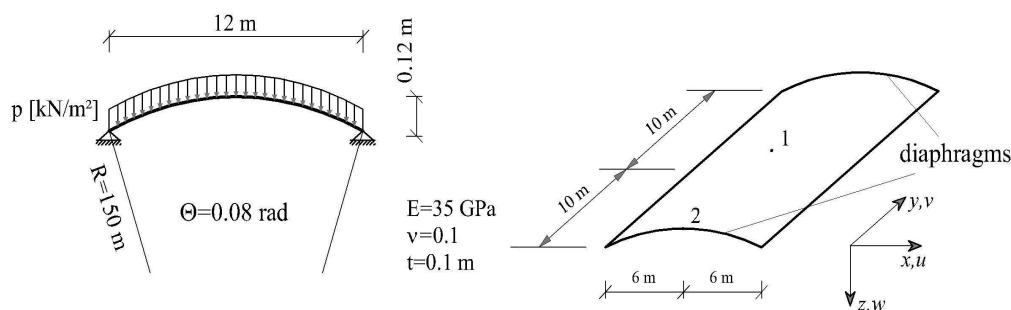

Figure 2 Geometric and material characteristics of shallow shell with load disposition

Finite element analysis is performed using the commercial software package Abaqus with the mesh of 1500 finite elements. STRI3 element of flat shell with six degrees of freedom per node is used. This element is the only one in Abaqus library which imposes Kirchhoff's assumption analytically [8]. Adopted model has 816 nodes which gives total of 4896 degrees of freedom used in analysis.

From presented results it is clear that analysed shell does not show snap-back, but only snap-through behaviour. Figure 3 shows excellent agreement of deflection of middle point for all three models. Slight discrepancy is observed for discretization D1. This discrepancy is more pronounced for longitudinal displacements, i.e. end shortening, given in Figure 4. Good correspondence of moments in the middle of the shell is observed in Figures 5 and 6. While moments M_x are almost identical, moments M_y show some differences. One of the most interesting graphs is given in Figure 7 where the increment of normal force N_x changes sign after the snap. The largest disagreement of the results occurs here, exclusively for the discretization D1. Similar observation can be made for the moments M_y , given in the Figure 8. Convergence of normal forces by number of finite strips and number of series terms is given in Figures 9 and 10. Convergences of quantities which require denser meshes are given intentionally. Moments and displacements converge much faster. According to this convergence tests, discretizations D1 and D2 are adopted. Convergence of normal forces in Abaqus is given in Figure 11, according to which the mesh of 1500 finite elements is adopted.

Discretization D1 gives excellent results before the second limit point is reached, i.e. just before hardening of the shell. However, for the normal forces, at the end of the loading, there are severe discrepancies and the D2 mesh is required for accurate values. This disagreements occur due to low degree of adopted polynomials and slow convergence of the function which describes structure end-shortening.

Discrete points which are designated on the graphs depend on adopted minimal and maximal arc-length. Desired smoothness of the curve can be obtained by variation of these parameters. It is

interesting to notice that it is a problem to obtain values of the desired quantity for the exact value of applied load because procedure always passes the complete load, 1-20 %, depending on the maximal arc length. Therefore, it was necessary to use very small arc-length in order to obtain presented results for convergence.

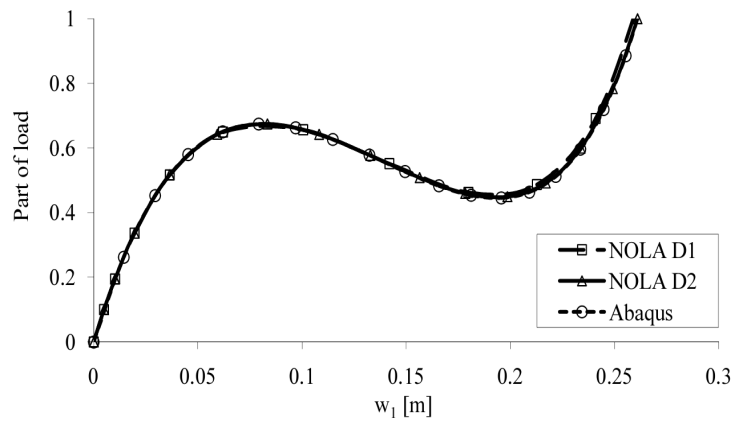

Figure 3 Comparison of deflection of shell centre

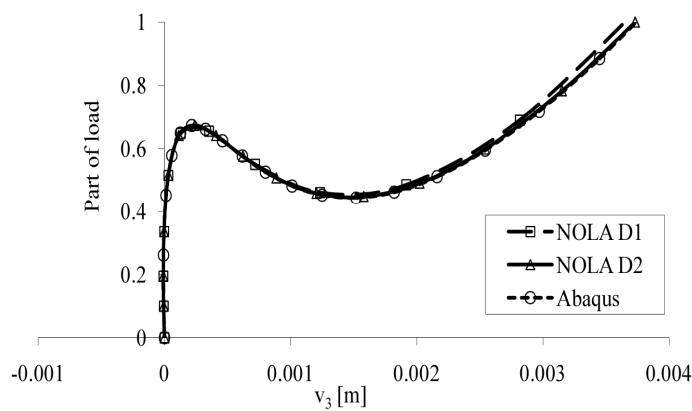

Figure 4 Comparison of longitudinal displacement component of point 2

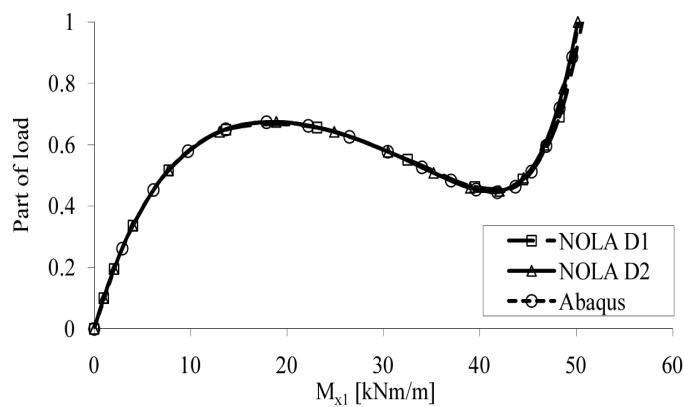

Figure 5 Comparison of moments M_{x1}

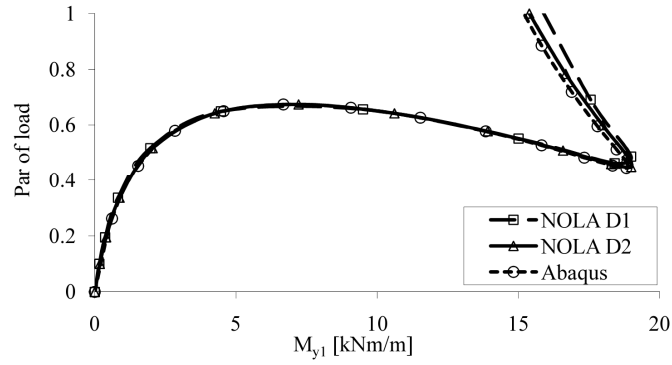

Figure 6 Comparison of moments M_{y1}

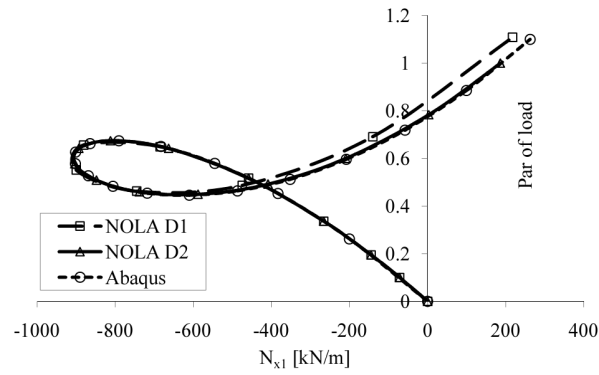

Figure 7 Comparison of normal force N_{x1}

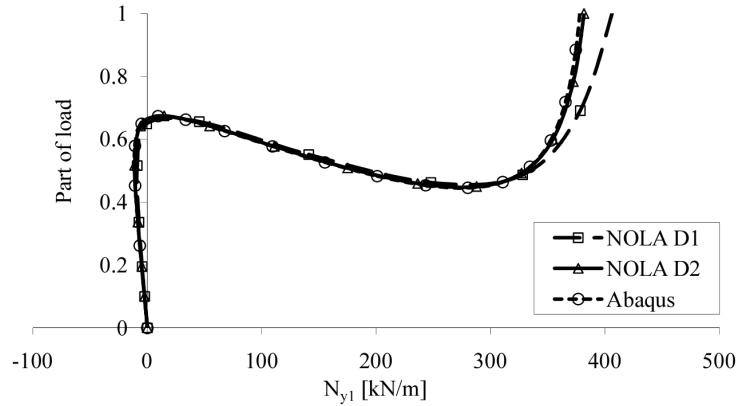

Figure 8 Comparison of normal force N_{y1}

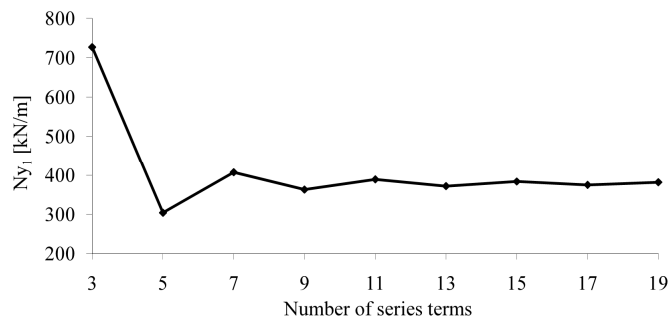

Figure 9 Convergence of normal force N_{y1} by number of series terms for discretization with 12 strips

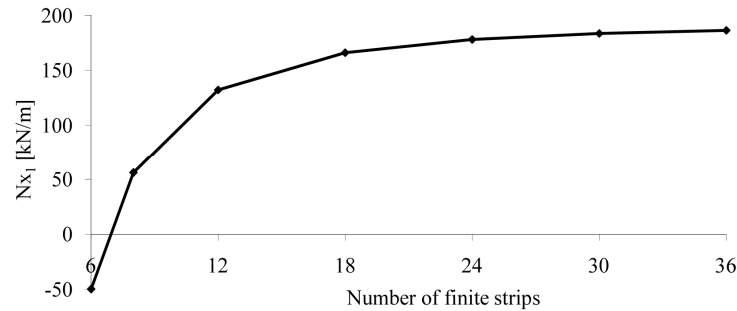

Figure 10 Convergence of normal force N_{x1} by number of strips for discretization with 15 series terms

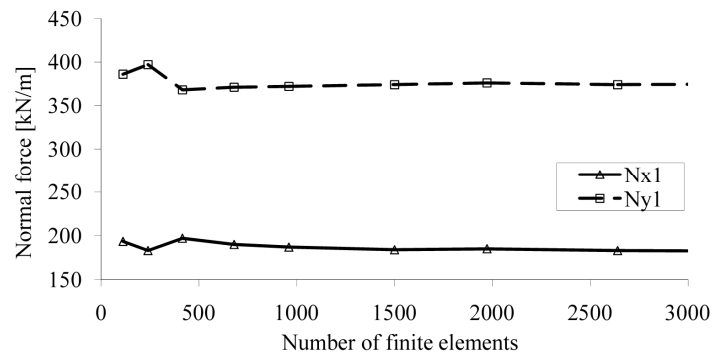

Figure 11 Convergence of normal forces at the shell centre by number of finite elements

CONCLUSION

Using the FSM with harmonic functions, complex behaviour of idealised elastic structures can be described. However, in order to obtain realistic structural response it is necessary to include effects of material nonlinearity. If the structural response is geometrically nonlinear, material will behave elastically for only few specific cases. Also, it is important to include influence of geometrical imperfections and non-ideal boundary conditions in order to describe structural behaviour. Appropriate introduction of all of these effects is a difficult task which is still not completely solved in structural analysis.

FSM and FEM give identical results if the modelling is done carefully. Definition of boundary conditions has the most influence on the relation of results of these methods. In order to reach same degree of accuracy FSM requires significantly less number of degrees of freedom, for some types of structures. Comparison of results between FEM and FSM with harmonic functions did not receive much attention in literature. According to available literature, snap analysis of shells, using the FSM with harmonic functions, is presented for the first time in this paper.

Further research will include definition of different boundary conditions, modelling of structures with longitudinally variable characteristics, and introduction of material nonlinearity.

Acknowledgement. Presented research is partially supported by the Ministry of Education, Science and Technological Development of the Republic of Serbia, Project No. TP 36008.

(Received 23. august 2013, accepted 20. september 2013)

REFERENCES

- [1] Crisfield, M. A. (2000). *Non-Linear Finite Element Analysis of Solids and Structures*. Chichester. John Wiley & Sons.
- [2] Cheung, Y. K., Tham, L. G. (1998). *Finite strip method*. CRC Press LLC.
- [3] Milašinović, D. D. (1997). *The Finite Strip Method in Computational Mechanics*. Subotica, Budapest, Belgrade. Faculties of Civil Engineering. Birografika.
- [4] Wang, S., Dawe, S. J. (1996). Finite strip large deflection and post-overall-buckling analysis of diaphragm supported structures. *Computers&Structures*, 61(1), 155-170.
- [5] Milašinović, D. D. Geometric non-linear analysis of thin plate structures using the harmonic coupled finite strip method. *Thin-Walled Structures* 49 (2), 280-290.
- [6] Yao, Z., Rasmussen, K. (2010). *Material and Geometric Non-linear Isoparametric Spline Finite Strip Analysis of Perforated Thin-Walled Steel Structures*. Sydney. Research Report No R910, The University of Sydney.
- [7] Borković, A., Mrđa, N., Kovačević, S., (2013). Dynamical analysis of stiffened plates using the compound strip method. *Engineering Structures*, 50, 56-67.
- [8] Abaqus, Theory manual, version 6.7, Dassault systems (2007).