

# Active Comb Filter Using Voltage Differencing Transconductance Amplifiers

Dinesh Prasad, Akshat Jain, Pankaj Dhingra and Aditya Panchal

**Abstract**— A new active comb filter employing Voltage Differencing Transconductance Amplifiers (VDTAs) is proposed to eliminate the selected frequencies of different signals. The proposed filter is based on VDTAs, capacitors and resistors. The functionality of the circuit is verified using PSPICE with TSMC CMOS 0.18 $\mu$ m process parameters for test signals of 50, 150, 250, and 350 Hz.

**Index Terms**— Active Comb Filter, Voltage differencing transconductance amplifier, Analog signal processing.

Original Research Paper  
DOI: 10.7251/ELS1620032P

## I. INTRODUCTION

THE field of biomedical signal analysis or processing has advanced to the stage of practical application of signal processing and pattern analysis techniques for efficient and improved noninvasive diagnosis and online monitoring of critical patients. Filtering of power line interference is very meaningful in the measurement of biomedical events recording, particularly in the case of recording signals as weak as the ECG (clinical tool for investigating the activities of heart). The most common are power line interference and baseline drift [1]. The fundamental frequency of this interference is usually 50 Hz or 60 Hz, depending on the local power-line frequency and often has heavy harmonic content above 50–60 Hz [2-5]. Power line interference around transformers is caused by stray magnetic fields causing the enclosure and accessories to vibrate. A phenomenon called “Magnetostriction” is also a source of vibration, where the core iron changes direction rapidly when magnetic field is applied. The intensity of the vibrations is a

Manuscript received 13 April 2015. Received in revised form 09 April 2016. Accepted for publication 17 June 2016.

This work was performed at the Advanced Analog Signal Processing Lab, Department of Electronics and Communication Engineering, Faculty of Engineering and Technology, Jamia Millia Islamia, New Delhi-110025, India.

Dinesh Prasad is with the Faculty of Engineering & Technology, Jamia Millia Islamia, New Delhi, India (phone: +91-11-26981284, e-mail: dprasad@jmi.ac.in)

Akshat Jain is with the Faculty of Engineering & Technology, Jamia Millia Islamia, New Delhi, India (phone: +91-11-26981284, e-mail: akshatjain119@gmail.com)

Pankaj Dhingra is with the Faculty of Engineering & Technology, Jamia Millia Islamia, New Delhi, India (phone: +91-11-26981284, e-mail: pankajdh.jmi@gmail.com)

Aditya Panchal is with the Faculty of Engineering & Technology, Jamia Millia Islamia, New Delhi, India (phone: +91-11-26981284)

function of the applied voltage. Hence physiological signal gets distorted by power line frequency and its harmonics.

Recently, the VDTA is a widely used active device for analog signal processing. In reference [6] the authors presented a CMOS structure of VDTA and its RF filter. There are many other applications of VDTA is reported in references [7-8] and references cited therein.

In this paper, a new design of active comb filter has been proposed consisting of VDTAs and few passive components to remove the harmonic interferences present in the various signals and functionality of the circuit is verified using PSPICE for test signals of 50, 150, 250, and 350 Hz.

## II. CIRCUIT DESCRIPTION

A 2<sup>nd</sup> order passive band reject filter is shown in Fig. 1. It consists of a series combination of R, L and C where the output is taken across the series combination of L and C.

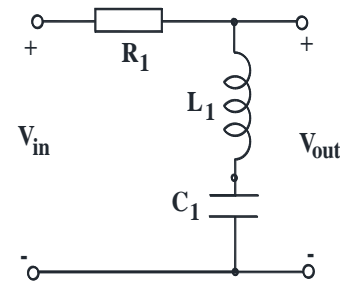

Fig. 1: RLC circuit of notch filter

The analysis of Figure 1 results in a voltage transfer function  $H(s)$  as:

$$\frac{V_o}{V_{in}} = \frac{s^2 + \frac{1}{LC}}{s^2 + s\left(\frac{R}{L}\right) + \frac{1}{LC}} \quad (1)$$

The parameters from the above transfer function are obtained as

$$\omega_0 = \sqrt{\frac{1}{LC}} \quad (2)$$

$$Q_0 = \frac{1}{R} \sqrt{\frac{L}{C}} \quad (3)$$

$$BW = \frac{R}{L} \quad (4)$$

Where,

$W_0$  is notch frequency of the filter.  
 $Q_0$  is quality factor of the filter.  
 $BW$  is the bandwidth of the filter.

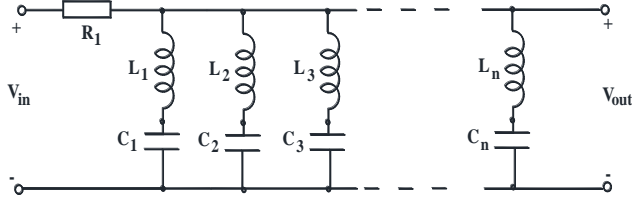

Fig. 2 Comb Filter using a basic RLC circuit

The extension of  $L$ - $C$  section of circuit in Fig. 1 gives a comb filter as shown in Fig. 2. It can eliminate  $n$ -number of harmonics of the power line interference, which distort the input signal  $V_{in}(t)$ .

By applying the circuit analysis technique in Fig. 2, we obtain the voltage transfer function of the active comb filter as:

$$H^k(s) = \frac{1}{\left( \frac{sC_k R}{s^2 L_k C_k + 1} + 1 \right)} \quad (5)$$

where the  $K^{th}$  notch filter is used to eliminate the  $K^{th}$  harmonic component from the input signal.

#### A. Proposed active comb filter

It is known that it is difficult to implement inductance in integrated circuits. Hence to overcome the above problem, the proposed comb filter is implemented using VDTAs. The notch filter is taken from the published paper [8]. When a series of notch filters using VDTAs are cascaded; there is a drastic reduction in the number of active components as compared to reference [9] as it uses 10 OTAs while our design uses just 4 VDTAs.

The symbolic notation of VDTA is shown in Figure 3.

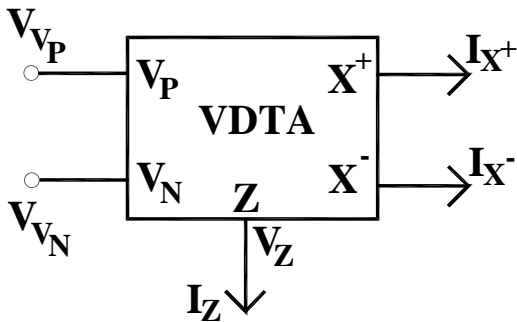

Fig. 3 Symbolic notation of VDTA

An ideal VDTA is characterized by following set of equations:

$$\begin{bmatrix} i_z \\ i_{x+} \\ i_{x-} \end{bmatrix} = \begin{bmatrix} g_{m1} & -g_{m1} & 0 \\ 0 & 0 & g_{m2} \\ 0 & 0 & -g_{m2} \end{bmatrix} \begin{bmatrix} V_p \\ V_n \\ V_z \end{bmatrix} \quad (6)$$

Where  $g_{m1}$  and  $g_{m2}$  are the transconductances of the VDTA.

The circuit of the notch filter using VDTA and passive component is shown in Figure 4[7]. Hence,  $Q_0$ , and bandwidth ( $BW$ ) can be adjusted electronically by using bias current of VDTAs. The proposed active comb filter using VDTAs which can eliminate four undesired frequencies is shown in Fig. 6. The expressions of the characteristic parameters of  $n^{th}$  notch filter are:

$$Q_n = \sqrt{\frac{g_{mn1} g_{mn2} C_n^2 R_n^2}{C_{n1} C_{n2}}} \quad (7)$$

$$\omega_n = \sqrt{\frac{g_{mn1} g_{mn2}}{C_{n1} C_{n2}}} \quad (8)$$

$$BW_n = \frac{1}{R_n C_n} \quad (9)$$

Where,

$Q_n$  is the quality factor of the  $n^{th}$  notch filter.

$W_n$  is the notch frequency of  $n^{th}$  notch filter.

$BW_n$  is the bandwidth of the  $n^{th}$  notch filter.

It can be seen that once the values of  $C_{n1}$ ,  $C_{n2}$  and  $R_n$  are fixed as per requirement, the notch frequencies can still be adjusted by varying  $G_{mn1}$  and  $G_{mn2}$  by changing bias currents of  $n^{th}$  VDTA.

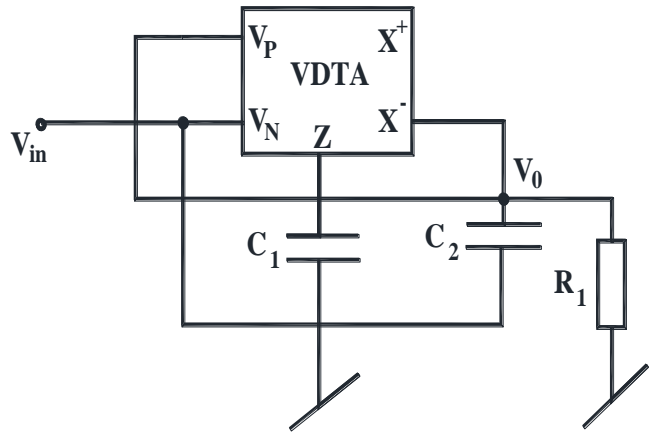

Fig. 4: Notch Filter using VDTA [8]

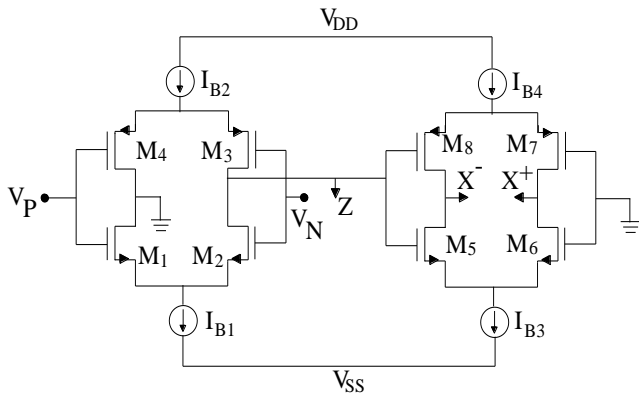

Fig. 5: CMOS implementation of VDTA [6]

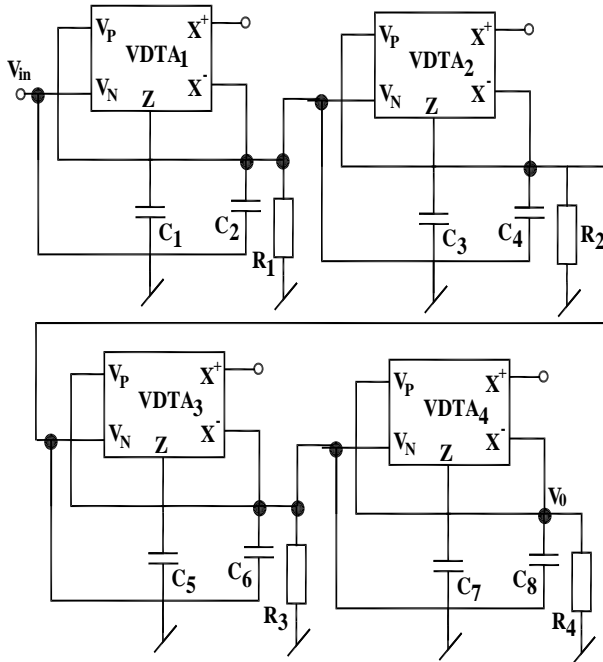

Fig. 6 Active comb filter using four VDTAs

### III. SIMULATION AND RESULTS

The VDTA has been simulated using PSPICE in CMOS Technology [6]. The internal structure of VDTA using TSMC CMOS technology is shown in Figure 5. The supply voltages used for simulation are  $V_{dd} = 0.9V$  and  $V_{ss} = -0.9V$ . The proposed comb filter is designed using four VDTAs so that it can remove four unwanted frequencies (harmonic frequencies). In power line interferences, odd harmonics interference plays an important role. So, in this paper, odd harmonics have been removed, that is first VDTA removes the fundamental frequency of 50Hz, then second VDTA removes third harmonic of 150Hz, then third VDTA removes fifth harmonic of 250Hz, then fourth VDTA removes seventh harmonic of 350Hz.

The values of the passive components used are  $C_1 = 466.184nF$ ,  $C_2 = 233.092nF$ ,  $R_1 = 70K$ ,  $C_3 = 155.394nF$ ,  $C_4 = 77.697nF$ ,  $R_2 = 75K$ ,  $C_5 = 93.225nF$ ,  $C_6 = 46.612nF$ ,  $R_3 = 150K$ ,  $C_7 = 66.595nF$ ,  $C_8 = 33.298nF$ ,  $R_4 = 400K$ .  $G_{m1}$  and  $G_{m2}$  of all the VDTAs are  $103.5\mu A/V$  for  $I_B = 10\mu A$ .

The time response of the input signals having frequencies 50Hz, 150Hz, 250Hz, and 350Hz and their corresponding outputs are shown in Figures 7, 8, 9 and 10 respectively. It can be seen from the graphs that the amplitude of the output sinusoidal signals (shown in green color) which is around 100mV is very small as compared to sinusoidal input signals (shown in blue color) of 1V at the above odd harmonics which means that the above frequencies are being highly attenuated. The frequency response of the comb filter is shown in Figure 11. The simulation results justify the validity of the structure.

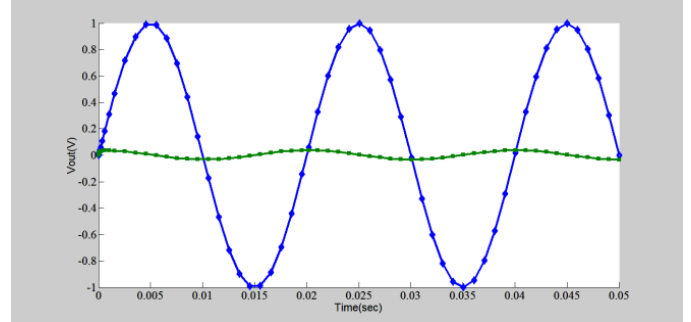

Fig. 7: Input and Output response at 50Hz

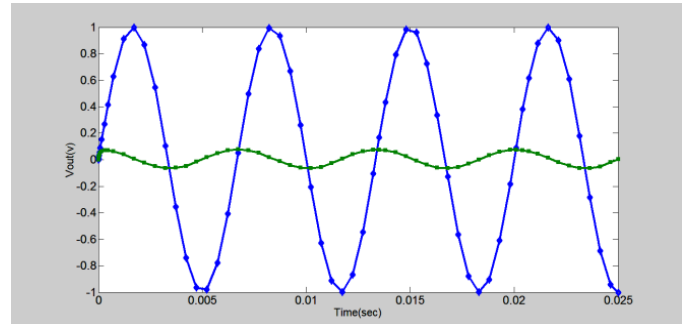

Fig. 8: Input and Output response at 150Hz

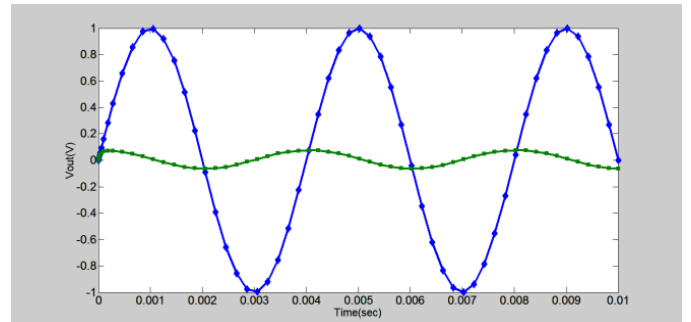

Fig. 9: Input and Output response at 250Hz

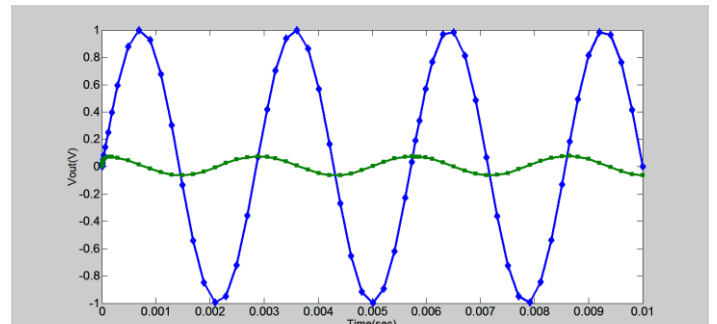

Fig. 10: Input and Output response at 350 Hz

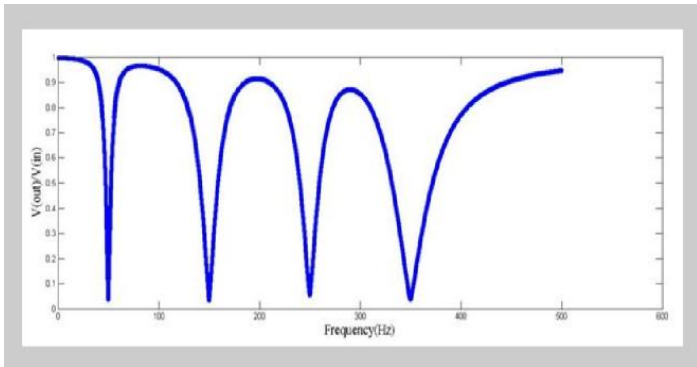

Fig. 11: Frequency response of active comb filter

#### IV. CONCLUSION

A new active comb filter employing voltage differencing transconductance amplifiers is proposed. The functionality of the circuit has been verified by using PSPICE with TSMC CMOS 0.18 $\mu$ m process parameters. The simulation graph of figure 11 has a comb like structure that is why it is called a comb filter. The simulated and theoretical results closely relate to each other.

#### REFERENCES

- [1] G. Kadam, P.C. Bhaskar, "Reduction of power line interference in ECG signal using fir Filter", *Int. J. of Comput. Engg. Rese.*, vol. 2, pp 315, 2012.
- [2] J. Piskorowski, "Power line interference removal from ECG signal using notch filter with non-zero initial conditions," in *Proceedings of the IEEE International Symposium on Medical Measurements and Application (MeMeA '12)*, pp. 1–3, University of Technology, Budapest, Hungary, May 2012.
- [3] S. M. M. Martens, M. M. Mischi, S. G. Oei, and J. W. M. Bergmans, "An improved adaptive power line interference canceller for electrocardiography," *IEEE Trans. on Biomedical Engineering*, vol. 53, no. 11, pp. 2220–2231, 2006.
- [4] T. W. Dawson, K. Caputa, M. A. Stuchly, and R. Kavet, "Pacemaker interference by 60-Hz contact currents," *IEEE Trans. on Biomedical Engineering*, vol. 49, no. 8, pp. 878–886, 2002.
- [5] C. T. Tsai, H.L. Chan, C. C. Tseng, and C.-P. Wu,, "Harmonic interference elimination by an active comb filter [ECG application]," in *Proc. of 16th Annual International Conf. of IEEE Engineering in Medicine and Biology Society*, vol. 2, pp.964–965, Baltimore, Md USA, November 1994.
- [6] A. Yesil, F. Kacar and H. Kuntman, "New Simple CMOS Realization of Voltage Differencing Transconductance Amplifier and Its RF Filter Application", *Radioengineering Journal*, vol. 20, No. 3, Sept., 2011.
- [7] D. Prasad and D. R. Bhaskar, "Electronically-Controllable Explicit Current Output Sinusoidal Oscillator Employing Single VDTA", *ISRN Electron.*, vol. 2012 (2012), article ID 382560, 5 pages.
- [8] D. Prasad, D. R. Bhaskar and Mayank Srivastava, "Universal voltage-Mode Biquad Filter Using a VDTA", *Indian Journal of Pure and Applied Physics*, vol. 51pp. 864-868, Dec. 2013.
- [9] R. K. Ranjan, S. P. Yalla, S. Sorya, and S. K. Paul, "Active Comb Filter Using Operational Transconductance Amplifier," *Active and Passive Electronic Components*, vol. 2014, pg- 4, 2014.