

Development of the Algorithm for Energy Efficiency Improvement of Bulk Material Transport System

Leposava Ristić, Milan Bebić, and Borislav Jeftenić

Abstract—The paper presents a control strategy for the system of belt conveyors with adjustable speed drives based on the principle of optimum energy consumption. Different algorithms are developed for generating the reference speed of the system of belt conveyors in order to achieve maximum material cross section on the belts and thus reduction of required electrical drive power. Control structures presented in the paper are developed and tested on the detailed mathematical model of the drive system with the rubber belt. The performed analyses indicate that the application of the algorithm based on fuzzy logic control (FLC) which incorporates drive torque as an input variable is the proper solution. Therefore, this solution is implemented on the new variable speed belt conveyor system with remote control on an open pit mine. Results of measurements on the system prove that the applied algorithm based on fuzzy logic control provides minimum electrical energy consumption of the drive under given constraints. The paper also presents the additional analytical verification of the achieved results through a method based on the sequential quadratic programming for finding a minimum of a nonlinear function of multiple variables under given constraints.

Index Terms—Conveyors, fuzzy logic, optimal control, energy efficiency, mining industry.

Original Research Paper
DOI: 10.7251/ELS1317030R

I. INTRODUCTION

ELECTRICAL energy consumption is increasing globally in order to keep improving our quality of life. Energy efficiency is today one of the key elements in energy policy of all developed countries in the world, because it contributes to the improvement of economy globally and extends the lifetime of conventional energy sources, since the greatest part of total electrical energy is generated by fossil fuels. In many countries, most electrical energy comes from coal, for example in Serbia, 62% of all capacities for energy production is in thermal power plants which use coal, and they produce 65% of total electrical energy production. In the following decades,

the focus will be on thermal power plants to further increase electrical energy capacities, requiring the rise of coal production.

In various branches of industry where bulk materials are produced or used, various types of belt conveyors (BCs) are used for the transport of materials. Continuous mining is used in large open pit mines (OPM), most often in mines where coal is excavated for use in thermal power plants. The mechanization in these types of mines is organized into systems, such as an ECS (excavator - belt conveyor - spreader) for excavating overburden, or an ECSY (excavator - belt conveyor - stock yard) for excavating coal. The BCs which are placed next to the excavator are called bench conveyors and their task is to receive the material from the excavator. The BC which transfers the material into the spreader is called the dump-side conveyor and BCs which connect the bench and dump-side conveyors are called connecting conveyors.

In recent times, very long BCs have been built with lengths of several dozen kilometers. Due to the length of the route and the necessity to shift the route regularly as a result of the technological demands a system of several BCs, i.e. BC stations are formed. BC stations are placed along the envisaged route so that material is transferred from BC to BC several times until it reaches the final destination. The installed power of these BCs is large and each rationalization of energy consumption can provide significant savings, which is naturally of significant interest for a user [1], [2], [3], [4].

There are two possibilities for energy savings in belt conveyors: first affects efficiency of drive components [5], [6], and second applies different control strategies of multi motor drives on belt conveyors [1], [2], [3], [7]. According to this, the paper presents the new BC system in an OPM, which transports overburden from the excavator to the spreader with the system of five BCs, with all aspects for energy efficiency improvement considered and applied in its realization. The belt drive of BC station is with a belt width of 2000 mm and has installed power of 4 MW, meaning the entire system has installed power of 20 MW. Modern belt conveyor systems are highly sophisticated systems which can be realized with remote control from the control centre of the OPM. Remote control makes full use of advances in modern technologies to increase safety, reliability and productivity levels. Control of

Manuscript received 12 April 2013. Received in revised form 24 May 2013. Accepted for publication 30 May 2013.

L. Ristić, M. Bebić and B. Jeftenić are with the Faculty of Electrical Engineering, University of Belgrade, Belgrade, Serbia (Leposava Ristić is corresponding author phone: +381-11-3218-364; fax: +384-86-81; e-mail: lela@etf.rs).

the BC system as a whole in the view of improved energy efficiency is possible only if the remote control is utilized.

Bulk material transported by a BC can be distributed along the length of the belt in various ways depending on how the material is deposited onto the conveyor. The quantity of material which is transported within a unit of time, or the average capacity, can be expressed with the general formula:

$$Q = \frac{1}{T} \int_0^T A(t) \cdot v(t) dt. \quad (1)$$

The instantaneous quantity of bulk material which is being transported using a BC depends on the operational mode of the system within which the BC is used. In a large number of cases, this quantity is variable and most often the instantaneous cross section area of material on the belt is less than the rated value. Since BC often operates at a decreased capacity, the same quantity of material can be transferred in two ways: with a constant rated speed (v_r) and smaller cross section of material on the belt ($A(t)$), or with rated cross section area of material (A_r), but at a lower than rated speed ($v(t)$), as shown in Fig. 1.

It has been shown in [1], that most often in practice $A(t) < A_r$, meaning that if the speed is modified according to (2), the BC could operate at a lower than rated speed.

$$v(t) = \frac{A(t)}{A_r} v_r \quad (2)$$

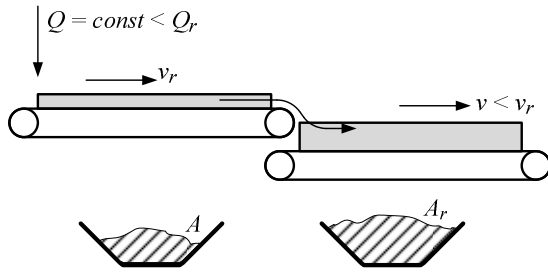

Fig. 1. Two BCs in a series connection - cross section of material on a belt.

Operation of conveyor at lower than rated speed would naturally lead to a decrease in the amount of energy needed to conduct transport [1], [2], [3], [8]. Therefore, if the speed is adjusted according to (2) for the transport of a certain quantity of material, savings of energy will be achieved based on the decreased power necessary for driving the belt.

The paper presents different algorithms which are developed for generating the reference speed of the system of belt conveyors as a function of instantaneous cross section of material on the belt, in order to achieve minimum electrical energy consumption but to avoid potential spillage of material, activation of electrical braking and unnecessary stress of belts and mechanical assemblies. Analyses performed on the detailed mathematical model of the conveyor with rubber belt indicate that the application of the algorithm based on fuzzy logic control will be the proper solution. The validation of the proposed idea is achieved through experimental results recorded on an existing system of belt conveyors in an open pit mine. The presented results are further compared with results of the other approach to optimum speed determination.

According to this approach, results for the optimum speed of BC are obtained „off - line” for the same incoming material, i.e. for the same input variable Q_{in} , applying the method of sequential quadratic programming and using the new identified function for average power of BC drive. It is proved that optimum speed is determined with both approaches, providing the minimum of electrical energy consumption under given constraints of the considered system of belt conveyors.

II. DEVELOPMENT OF THE ALGORITHM FOR GENERATING REFERENCE SPEED OF BELT CONVEYOR DRIVE

A. Algorithm with Constant Deceleration

Speed control of a BC requires information about the quantity of material which is deposited onto the belt, meaning the instantaneous capacity must be known.

The instantaneous capacity is:

$$Q(t) = \frac{dV(t)}{dt} = A(t) \cdot v(t) = A(t) \cdot v_{const} \sim A(t). \quad (3)$$

The speed of the belt onto which the material is deposited should be modified in accordance with (2) in order to achieve the defined criteria of speed control. However, the instantaneous capacity changes quite frequently and sporadically. This means that the speed should be increased and decreased in the same manner as the instantaneous capacity changes. These dynamic processes would be unfavorable for the mechanical assemblies of a BC, especially for the belt, and could lead to increased energy consumption.

Because of the fact that the instantaneous capacity changes and those changes cannot be predicted, the control algorithm must be such that the belt speed is adjusted to the conditions at the beginning of the conveyor, i.e. at the location where the instantaneous capacity is measured.

The algorithm for generating the reference speed of the belt drive with constant deceleration is defined as follows:

1. The theoretical belt speed is calculated on the basis of the equation (2), and can be expressed as its special case when a BC in the system of BCs is considered:

$$v_t(t) = \frac{A_{in}(t)}{A_r} v_{in}(t). \quad (4)$$

In (4) $A_{in}(t)$ and $v_{in}(t)$ are the instantaneous value of cross section of incoming material and the instantaneous speed of the previous belt.

The actual reference speed of the belt drive $v_{ref}(t)$ is calculated on the basis of (4) according to (6) under the conditions defined by (5):

$$\frac{dv_t(t)}{dt} \geq 0 \quad \text{and} \quad v_t(t) - v_{ref}(t) \geq \varepsilon, \quad (5)$$

$$v_{ref}(t) = c \cdot \int (v_t(t) - v_{ref}(t)) dt + v_{ref}(t_1), \quad (6)$$

where t_1 is the moment when both conditions defined by (5) are acquired, c and ε are constants with dimensions $[s^{-1}]$ and $[\%]v_r$ respectively, while dv_t/dt is time derivative of theoretical belt speed with the dimension of $[s^{-1} \cdot \%]v_r$.

2. When the conditions from (5) are not fulfilled, i.e.

$$\frac{dv_t(t)}{dt} < 0 \quad \text{and} \quad v_t(t) - v_{ref}(t) < -\varepsilon, \quad (7)$$

the actual reference speed is determined on the basis of (8),

$$v_{ref}(t) = v_{ref}(t_2) - k \cdot (t - t_2), \quad (8)$$

where t_2 is the moment when at least one of the conditions from (7) ceases to be valid and k is deceleration.

If it is desired for the BC to constantly operate at the rated speed, then, using the „Operating mode” signal, the status of switch P2 is selected as „0”, and then the reference speed is determined using the expression (9).

$$v_{ref}(t) = c \cdot \int (v_r - v_{ref}(t)) dt + v_{ref}(t_3) \quad (9)$$

Block diagram of the described algorithm is shown in Fig. 2. During the period when the quantity of material coming onto the conveyor increases, the reference speed of the drive is determined according to (6), and at that time the drive accelerates. The constant c determines the dynamic of reference speed. In this manner the cross section of the material on the speed controlled belt increases, meaning it gravitates towards A_r . When the quantity of incoming material decreases, the reference speed is calculated based on (8), i.e. the speed decreases with a deceleration k . The speed adjustment range is limited, minimum speed should be 50% of the rated speed; the maximum speed is set at 100 - 125%, dependant on the capacity of excavator and working conditions.

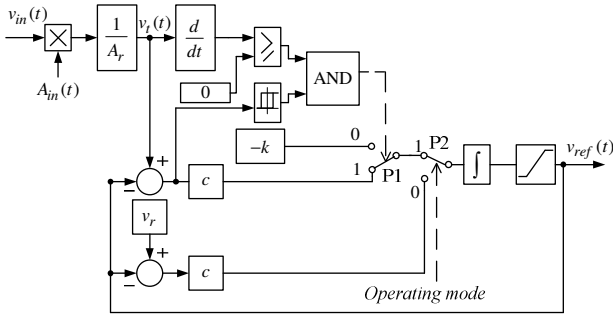

Fig. 2. Algorithm for generating the reference speed of the belt with constant deceleration.

When material is deposited to the beginning of the belt at a constant speed (v_{const}), then the cross section area of material at the transfer point is proportional to the instantaneous capacity of the material which is being deposited. In this case, the capacity which is obtained in this manner is proportional to $A_{in}(t)$. If it is not the case, i.e. the material is deposited to the beginning of the belt at a speed which is not constant, but is the result of the algorithm shown in Fig. 2, then the cross section area of material at the transfer point must be calculated in accordance with the conservation of capacity, as in (10), for the transfer point between two BCs, $(i-1)$ and i -th,

$$A_{(i)in}(t) = \frac{A_{(i-1)out}(t)}{v_{(i)}(t)} \cdot v_{(i-1)}(t). \quad (10)$$

According to (10), the cross section at the end of the $(i-1)$ belt must be determined. Calculation is conducted by

„monitoring” the movement of material along the belt over time. This can be performed by dividing the belt into sections of constant length. The length of these sections is determined so that a constant cross section of material can be observed along its entire length. The cross section area of material on one such section is entered into the memory, i.e., registry. The number of registries R is:

$$R = \frac{L}{L_{regi}} \in \mathbb{N}. \quad (11)$$

The upper side of the belt, meaning the side where the material is located, is represented by series containing an R number of registries. Entering of data into the registry is done in accordance with the selection time which corresponds to the time necessary for the belt to travel a distance of L_{regi} . The time when the data is entered (the sampling instant) is determined using a logical block with a resettable integrator, according to (12). The registries are organized in a series so that at the sampling instant the earlier recorded values are shifted into the next registry and new value is entered into the first registry.

$$trigger = \begin{cases} 0 & \int v(t) dt < L_{regi} \\ 1 & \int v(t) dt = L_{regi} \end{cases} \quad (12)$$

The constant k determines the deceleration of the drive which must confirm with the dynamic characteristics of the drive. An abrupt deceleration unfavorably affects all mechanical assemblies, couplings, bearings, the belt, etc. BC drives with a route which does not traverse an incline use braking with a resistor and chopper in the DC circuit. An abrupt deceleration would lead to the activation of the electric braking system whereby the braking energy would unnecessarily transform into heat within the resistors.

Regarding these conditions and constraints a value for constant k is empirically determined and applied in the algorithm for generating the reference speed of the belt on the system of five belt conveyers in an open pit mine. The results of measurements performed on the system are given in [4]. These results show that the maximum value of the material cross section on the belt is not achieved due to two reasons: the minimum speed is limited to 50% of the rated speed and the speed does not exactly follow the reduction of the instantaneous material cross section on the belt due to constant value of deceleration. As the absolute value of constant k decreases, the deviation from the maximum material cross section increases, but the activation of the electric braking system is avoided in all modes of operation, except in the case of emergency stop. Therefore, the system of belt conveyors does not operate with maximum efficiency.

B. Algorithm with Fuzzy Logic Control of Instantaneous Material Cross Section on the Belt: FLC - Case A

To further improve the algorithm for generating reference speed, modifications concerning deceleration k should be analyzed. Based on analytical considerations and results of simulations performed on mathematical model of belt

conveyor, it can be concluded that average power and average belt speed under the given constraints, have their minimum values if the belt runs with speed proportional to material at its input, i.e. with the theoretical belt speed $v_i(t)$. In this case, during the period of deceleration, time derivative of speed will have its maximum absolute value, hence further increase will cause spillage of material over the belt. Also, in cases when value of incoming material cross section onto the belt has big or frequent variations, this maximum absolute value of time derivative of speed during deceleration can activate electric braking system and therefore, it could not be allowed.

When reference speed of BC is the result of the applied algorithm with constant deceleration, the BC drive starts to decelerate always when the condition $dv_i(t)/dt < 0$ is fulfilled, consequently reducing the range of BC operation with the theoretical belt speed $v_i(t)$. To improve the algorithm for generating reference speed, the range of BC operation with the theoretical belt speed $v_i(t)$ must be extended.

As nonlinear system is to be controlled, the control methodology has to be nonlinear, too. Therefore, the authors of the paper propose different methodology to develop the algorithm for generating the reference speed of the belt, which is based on fuzzy logic control of instantaneous material cross section on the belt, since the adjustment of belt speed is in accordance to the variance of instantaneous material cross section on the belt.

Fuzzy logic based control has been successfully employed in the large number of scientific and engineering applications, as well as numerous commercial applications and industrial systems. In this paper, a knowledge based control algorithm, called fuzzy logic control is proposed to solve the minimization problem, i.e. to drive the system with minimum electrical power, meaning to convey the maximum cross section of material at optimum speed.

The block diagram of the algorithm with fuzzy logic control of instantaneous material cross section on the belt is shown in Fig. 3. As explained earlier, the material which is deposited onto the beginning of each speed controlled BC in the system is not measured then calculated. In accordance with (10), fuzzy control which is found to calculate the speed reference of each BC in the system requires three values to be provided: speed of the observed BC, speed of the previous BC and cross section of incoming material from the previous BC. All of them are achieved with SCADA system.

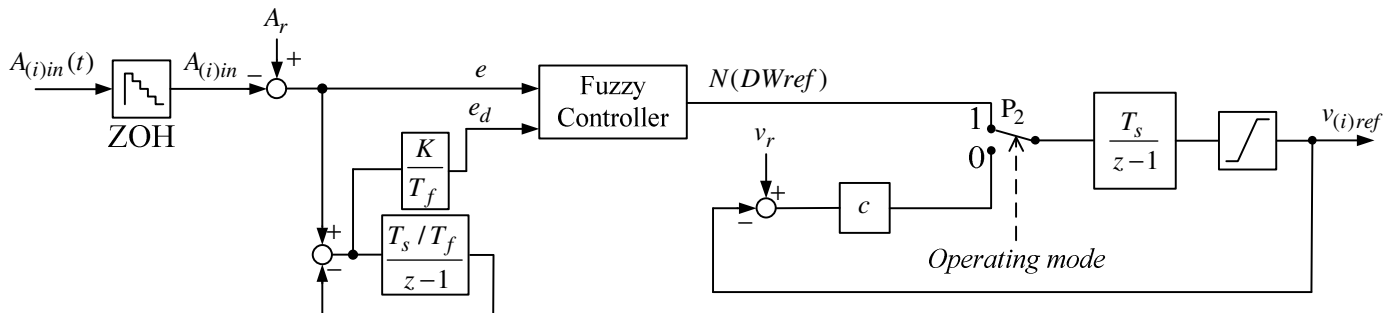

Fig. 3. Algorithm for generating the reference speed of the i -th BC in the BC system with FLC - case A.

As it can be seen from Fig. 3, the FLC - case A has two inputs: the first input e , which presents the deviation of the instantaneous material cross section from the rated value and the second e_d , which presents the derivative of the first input. The „practical differentiator” is applied for the variable e_d , to provide derivation and filtration of the variable e in the same time, instead of using these two functions separately. T_s is sample time, T_f is time constant of discrete filter and K is constant which adjusts the value of variable e_d to its universe of discourse. FLC - case A has single output variable $N(DWref)$, which presents an increment of the reference speed, generated from fuzzy rule base given in Table I. Membership functions for the input e are given in Fig. 4, membership functions for the input e_d , are given in Fig. 5, and membership functions for the output $N(DWref)$ are given in Fig. 6.

Values for input and output variables are normalized with base values selected in accordance with rated parameters of motor and the belt conveyor, given in the Appendix. FLC - case A is based on Mamdani's reasoning methods, developed using Fuzzy Logic Toolbox [9] and integrated into Matlab Simulink dynamic model of BC, which is presented in [10].

TABLE I
FUZZY RULES FLC - CASE A

$e_d \backslash e$	N	NS	ZE	P
N	P	PS	PS	PS
ZE	PS	PS	ZE	NS
P	ZE	ZE	NS	NS

In the process of fuzzification, the universe of discourse for linguistic variable e is mapped in the $[-1, 1]$ interval and divided into 4 fuzzy sets: negative (N), negative small (NS), zero (ZE) and positive (P). The universe of discourse for the linguistic variable e_d is mapped in the $[-0.5, 0.5]$ interval and divided into 3 fuzzy sets: negative (N), zero (ZE) and positive (P). The universe of discourse for the linguistic variable $N(DWref)$ is mapped in the $[-0.3, 1]$ interval and divided into 4 fuzzy sets: negative small (NS), zero (ZE), positive small (PS) and positive (P). The MIN-MAX method is used for fuzzy rules processing, while the centre of gravity method is used for defuzzification.

The desired performance of the system is accomplished with small number of fuzzy sets per variable. This reduces the size of table of fuzzy rules and simplifies the implementation. Considering rules given in the Table I, it can be concluded that the reduction of speed is applied only in three cases: when instantaneous material cross section on the belt has smaller than maximum value (variable e is P) and this value decreases or stays unchanged (variable e_d is P or ZE). In all other cases speed reference is increased or kept unchanged, in order to avoid spillage of material over the belt.

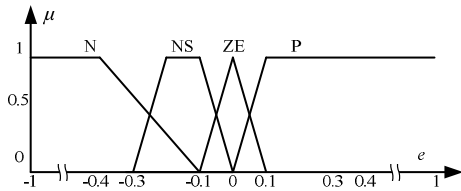

Fig. 4. Membership functions for input variable e .

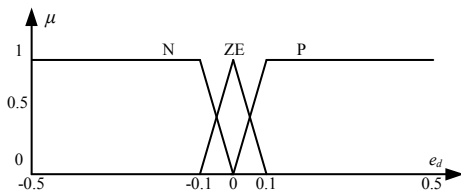

Fig. 5. Membership functions for input variable e_d .

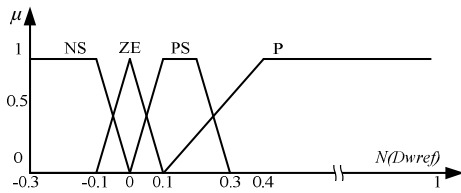

Fig. 6. Membership functions for input variable $N(DWref)$.

The performance of the algorithm is tested in cases which best illustrate the developed control strategy, with actual constraints of the system considered and added into the simulation conditions. Results of simulations are given in Fig. 7. In the observed system of five BCs, the first two BCs are bench conveyors and are running at constant speed, while the other three have the speed reference generated with the proposed algorithm. The third BC in the system is considered. The material cross section is measured at the end of the second belt, A_{2out} . The following simulation was conducted: the belt with incoming material of 20% was started with rated speed, then the speed control was turned on at time $t = 40s$; then the incoming material was increased to 90% of rated value, and at the end, the incoming material was suddenly decreased to the starting value. The presented results show that during the instantaneous and short – term increase of the incoming value of material cross section on the third belt, the control algorithm provides maximum acceleration in order to avoid spillage of material over the belt. Also, the control algorithm provides maximum deceleration, but without braking in the case of sudden decrease of incoming flow of material on the BC.

The other test of the applied control strategy is performed on the mathematical model, too. In this case, time dependency

of the incoming material is with a sine component $A_{in}(t) = A_{av} + A_{sin} \cdot \sin((2 \cdot \pi / T_{sin}) \cdot t)$. This signal is selected to simulate the way in which the excavator is depositing material on the BC. Again, the presented results of simulation in Fig. 8 show that the value of the material cross section on the BC is maintaining maximum. Small variations around the maximum value are due to lagging of actual BC speed to reference speed, which follows the shape of material, with required acceleration and maximum deceleration – without braking.

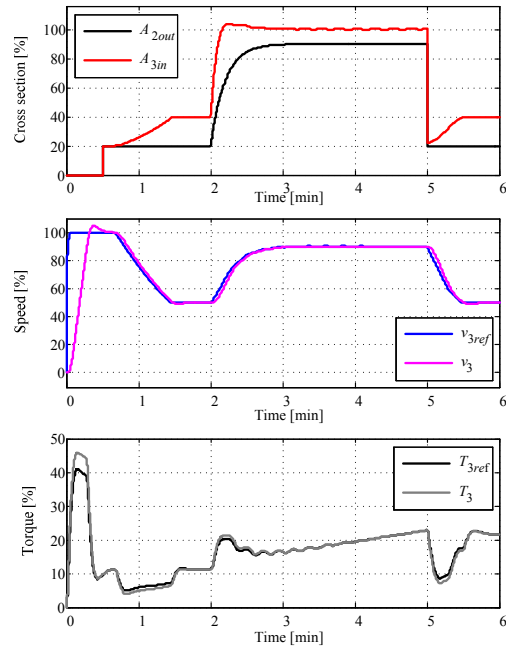

Fig. 7. Characteristic values of the third belt with FLC - case A: transition period from constant speed operation to controlled speed operation with changes of the incoming material from 20% to 90% of rated value and vice versa, in a realistic way that can be expected in practice.

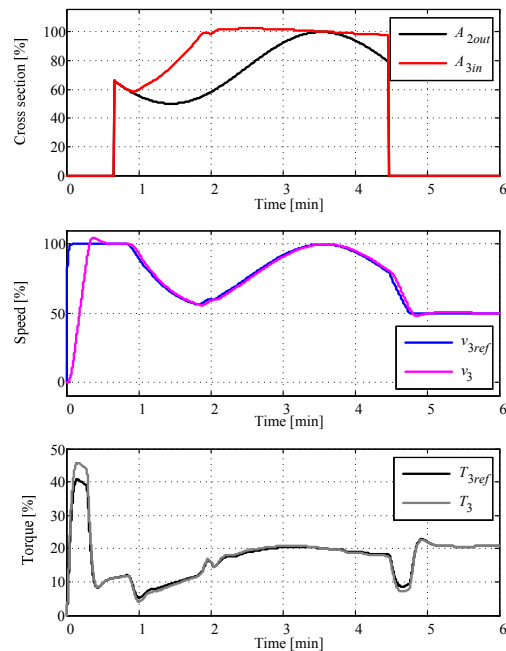

Fig. 8. Characteristic values of the third belt with FLC - case A: transition period from constant speed operation to controlled speed operation with sinusoidal changes of the incoming material.

The algorithm is generating the speed reference based on information of instantaneous value of incoming material cross section onto the belt, without the information about variable motional resistances which are the result of various quantities of material on the belt, different weather conditions and the condition of equipment. This can be a problem, which may cause the activation of electrical breaking system. The required information is included in the information about the instantaneous value of the drive torque. Hence, this value must be considered in order to provide precise control of the reference speed.

C. Algorithm with Fuzzy Logic Control Which Incorporates Drive Torque: FLC – Case B

Due to aforementioned reasons, k should be variable to provide deceleration with drive torque nearly zero (but not negative) and therefore operation with minimum energy consumption. It can be determined using the expression (13), derived from the Newtons law,

$$k(t)_{oe} = \frac{T_l(t)}{J_\Sigma(t)} \quad (13)$$

where $J_\Sigma(t)$ is the total inertia referred to motor shaft, including the effect of material mass. In accordance with DIN22101 standard, T_l can be expressed as

$$T_l(t) = T_{l0} + T_l(m_{bm}) \quad (14)$$

where T_{l0} is constant part of the total load torque and $T_l(m_{bm})$ is a part which is a function of mass of the material on the belt and consequently time dependant. Similar can be derived for the total moment of inertia of the loaded belt conveyor,

$$J_\Sigma(t) = J_{\Sigma 0} + J_\Sigma(m_{bm}), \quad (15)$$

where $J_{\Sigma 0}$ is a constant part of the total moment of inertia and $J_\Sigma(m_{bm})$ is a part proportional to mass of the material on the belt and is also time dependant.

The constant part of the load torque, as well as the constant part of the moment of inertia, can be calculated with sufficient accuracy. The values can also be updated from time to time to account for changes in the system of BCs, due to changes of length or changes in condition of the equipment. However, components of load torque and moment of inertia remain unknown since they are functions of mass of material on the belt and external conditions. This leads to inaccurate calculation of k and inappropriate deceleration of a BC.

Due to aforementioned facts, it can be derived that the

optimum value for $k(t)$ has to fulfill following three criteria:

1) the absolute value of $k(t)$ must be less than absolute value of $\Delta A_{in}/\Delta t$ in the period of deceleration, in order to avoid spillage of material over the belt,

2) technical criteria, $|k(t)| \leq k_{max\ technical} = 3.5 [s^{-1} \cdot \%] v_r$, in order to keep stress of belts and mechanical assemblies during the deceleration within tolerance and

3) the criteria for optimum energy consumption under given constraints of the system, defined with (13).

The value $k_{oe}(t)$ must not be applied during periods of deceleration when $|k_{oe}(t)| > k_{max\ technical}$. For this reason, motors of the multi motor drive of BC have to develop torques in accordance with (16).

$$T_e \geq k_{max\ technical} \cdot J_\Sigma(t) - T_l(t) \quad (16)$$

The expression (16) leads to the conclusion that measured value of the drive torque has to be incorporated in the algorithm for generating reference speed, in order to provide operation of the system with optimum $k(t)$, within existing operating conditions. This value is achieved with SCADA system, meaning that it is always available.

Fuzzy control was found to calculate acceleration and deceleration, based on measuring three values: speed of previous BC, cross section of incoming material, and the drive torque. The block diagram of the algorithm for generating the reference speed of BC with FLC – case B is shown in Fig. 9. As it can be seen from Fig. 9, FLC – case B has two inputs: $Dwref$ according to (17),

$$Dwref_{(n)} = v_{t(n)} - v_{ref(n-1)}, \quad (17)$$

and the drive torque Te . The task of maintaining the torque of the motor at a zero value during periods of deceleration is now provided by the FLC – case B. Therefore, the deceleration is achieved while avoiding all the problems caused with the parameters variation due to external conditions. The FLC – case B is with single output $N(Dwref)$. It is based on Mamdani's reasoning methods, developed using *Fuzzy Logic Toolbox* [9] and integrated into *Matlab Simulink* dynamic model of BC, which is presented in [10], as well as FLC – case A.

Membership functions for the input $Dwref$ are given in Fig. 10, membership functions for the input Te are given in Fig. 11, and membership functions for the output $N(Dwref)$ are given in Fig. 12.

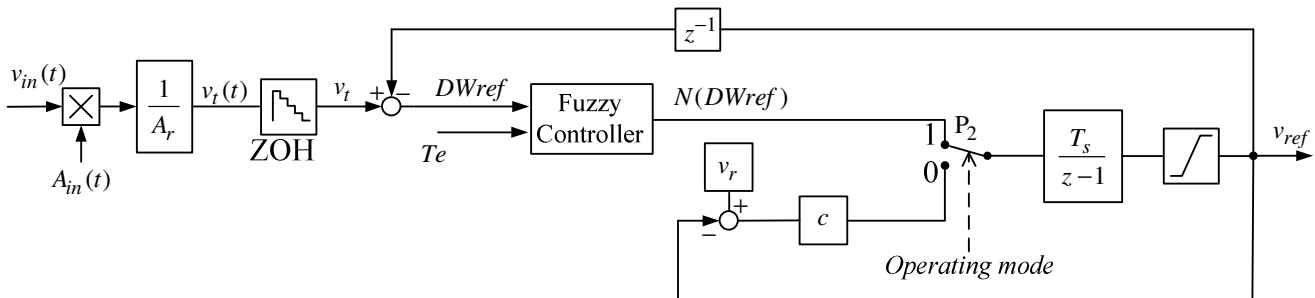

Fig. 9. Algorithm for generating the reference speed of the belt with FLC – case B.

The output variable $N(Dwref)$ is increment of the reference speed, generated from fuzzy rule base given in Table II. Values for input and output variables are normalized with base values selected in accordance with rated parameters of motor and the belt conveyor, given in the Appendix, as well as for the FLC – case A.

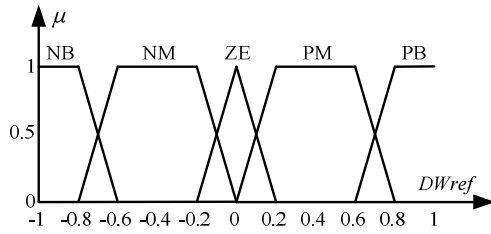

Fig. 10. Membership functions for input variable $Dwref$.

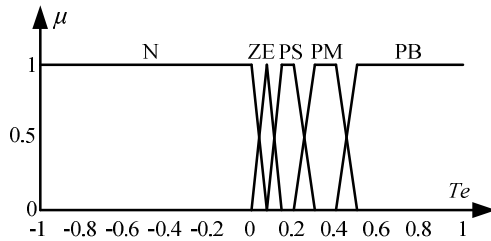

Fig. 11. Membership functions for input variable Te .

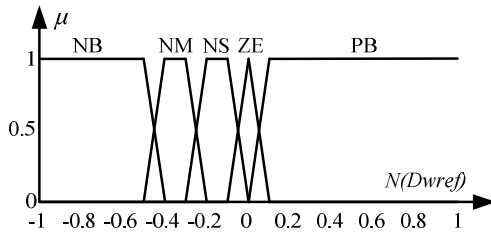

Fig. 12. Membership functions for output variable $N(Dwref)$.

In the process of fuzzification, the universe of discourse for linguistic variables $Dwref$, Te and $N(Dwref)$ is mapped in the $[-1, 1]$ interval and divided into fuzzy sets: negative (N), negative big (NB), negative medium (NM), zero (ZE), positive small (PS), positive medium (PM), and positive big (PB). The MIN-MAX method is used for fuzzy rules processing, while the center of gravity method is used for defuzzification.

Considering Table II, three regions can clearly be distinguished and described with fuzzy rules as follows:

- If (Te is N) then ($N(Dwref)$ is ZE) - meaning that if drive torque approaches zero, the reference speed increment must converge to zero in order to avoid activation of electrical braking;

- If ($Dwref$ is ZE) then ($N(Dwref)$ is ZE) - meaning that if the required change of reference speed is small (zero), then no change of the output value (reference speed increment) is needed, regardless of drive torque value;

- If ($Dwref$ is PM) then ($N(Dwref)$ is PB) or

- If ($Dwref$ is PB) then ($N(Dwref)$ is PB) - meaning that if incoming material on the belt is increasing, the BC drive must achieve proper acceleration in order to avoid spillage of material over the belt.

TABLE II
FUZZY RULES FLC - CASE B

$Te \backslash Dwref$	N	ZE	PS	PM	PB
NB	ZE	NS	NM	NB	NB
NM	ZE	ZE	NS	NM	NB
ZE	ZE	ZE	ZE	ZE	ZE
PM	ZE	PB	PB	PB	PB
PB	ZE	PB	PB	PB	PB

The desired performance of the system was accomplished with only five fuzzy sets per variable. This reduces the size of table of fuzzy rules. Distribution of fuzzy sets depends on the requirements of the system. Also it provides adequate control sensitivity. For the input variable Te , a single fuzzy set „N” denotes braking which should be avoided. When torque is close to zero, high control sensitivity is required, therefore narrow fuzzy sets are defined. For any positive value of the Te , when the input variable $Dwref$ is positive, the FLC - case B gives big value at the output in order to avoid spillage of material on the belt. For small variations of input variable $Dwref$, i.e. small variations of material cross section at the input of the BC (A_{in}), the system has no sudden change of the output variable, which is provided with the adequate tuning of the „ZE” fuzzy sets. The shape of generated control function is given as a surface in Fig. 13. This form is suitable for implementation in PLC as look up table with interpolation between the calculated points.

The described algorithm with FLC - case B for generating the speed reference is developed and tested on the detailed mathematical model of the drive system with the rubber belt [5]. The rule base is fully defined and the controller generates the output within the system limits for every combination of input variables. The systems equipped with smart features which adjust the response of the system under the effect of any unseen loading conditions should be much safe and reliable. Therefore, an adaptive fuzzy controller must be developed [11], which can be the topic of authors' future work.

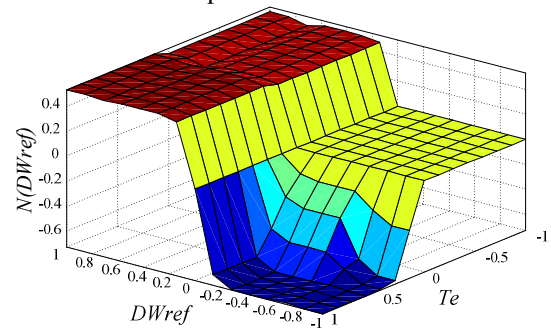

Fig. 13. The shape of generated control function.

The results of measurements of the implemented algorithm on the dump-side conveyor on the new variable speed BC system with remote control on an OPM are presented in Fig. 14. The speed is adjusted in the range from 60% to 100% of the rated speed, as the user demanded. The cross section value of incoming material to the dump-side BC (A_{4out}) is

calculated, not measured. Discretization of the input material cross section at the transfer point between two BCs influences all other characteristic values of BC, which are archived with SCADA and presented in Fig. 14.

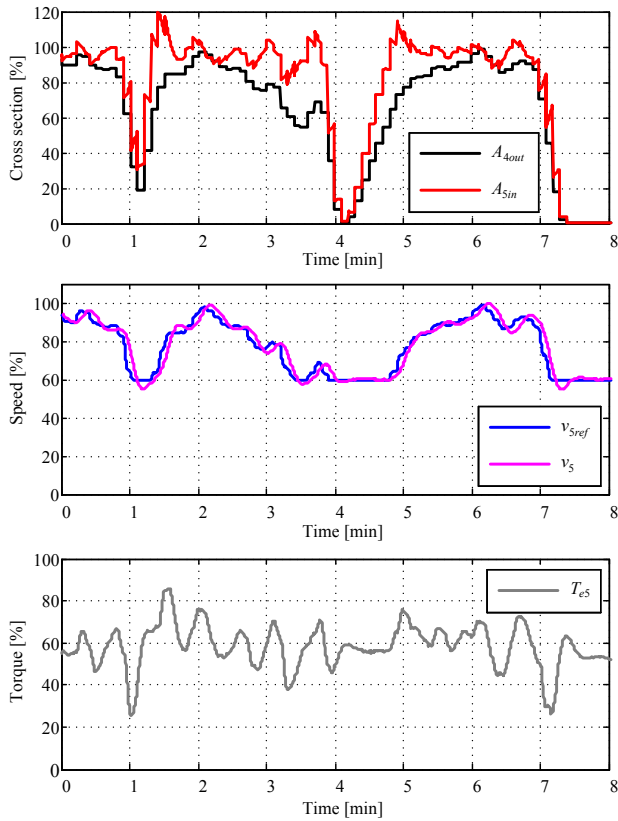

Fig. 14. Characteristic values of the dump-side BC: implementation of the algorithm for generating the reference speed of the belt with FLC - case B (speed control in the range of 60% to 100% v_r).

It has been shown by experimental results presented in Fig. 14 that the control strategy with FLC - case B adjusts the speed of the loaded BC in accordance with the quantity of material on the belt, in order to achieve energy saving in normal operation. Variable acceleration and deceleration is performed in such a way to cause minimum stress of mechanical assemblies and the belt. It can also be noticed from presented results that the cross section of material on the belt is sometimes greater than 100% which is the maximum theoretical value. Even when the value of the cross section reaches 116% of the theoretic value, transport can still be conducted without spillage [8].

The measurements which were taken over a longer period of time on a system with an installed power of 20MW confirmed the expected savings in electrical energy consumption. The system operated while alternating between speed control and constant speed, each for several hours. Twenty series of measurements were generated in various exploitation conditions. Data was collected for a period of eight months for three BCs in the system. Fig. 15 provides the data for average power in the individual series of measurements, and Fig. 16 provides data on consumption of electrical energy per cubic meter of transferred overburden. The displayed results show

the reduction of both, average power [MW] and average value of specific energy [kWh/m³], in the range from 3% to 19%, comparing to constant speed operation. Hence, the measurements unequivocally confirm the advantage of speed control on BCs, which results in reduced energy consumption.

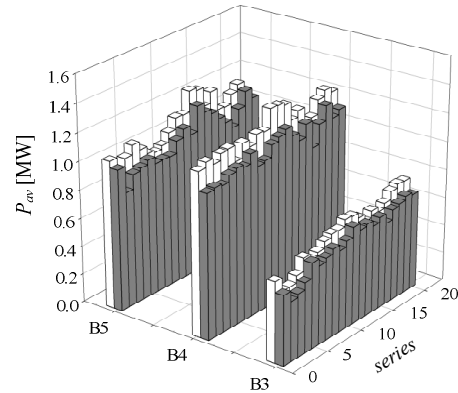

Fig. 15. Average power consumption of belt drives in [MW], on the third, fourth and fifth BC station (B3, B4 and B5): white bars - constant speed operation, grey bars - variable speed operation with FLC - case B.

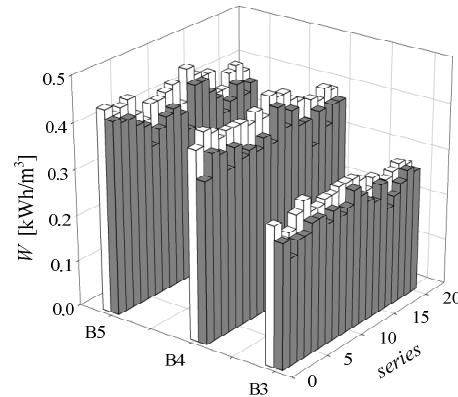

Fig. 16. Consumption of Energy per m³ [kWh/m³], on the third, fourth and fifth BC station (B3, B4 and B5): white bars - constant speed operation, grey bars - variable speed operation with FLC - case B.

III. THE OPTIMUM SPEED GAINED WITH FLC - CASE B: ANALYTICAL VERIFICATION

A function of mechanical power of belt conveyor drive is developed based on DIN 22101 methodologies for motional resistances calculation. It is presented in [2] as a new „energy model”, which lumps all the parameters into four coefficients, θ_1 , θ_2 , θ_3 and θ_4 . The procedure for least square (LSQ) based „off - line” parameters estimation has been applied to identify coefficients of „energy model” of the observed dump-side BC. The required speed has also been determined using the method of sequential quadratic programming, with the goal to reduce the electrical energy consumption under defined constraints of the system. The result achieved in this way, has been compared with the result of the applied algorithm with FLC - case B.

Mechanical power of the BC drive as a function of capacity and speed, for the defined operating conditions, i.e. „energy model” is given with (18),

$$P(T, v) = \theta_1 \cdot T^2 \cdot v + \theta_2 \cdot v + \theta_3 \cdot \frac{T^2}{v} + \theta_4 \cdot T + \frac{v^2 \cdot T}{3.6} \quad (18)$$

where P [W] is mechanical power, v [m/s] is speed and T [t/h] is mass flow, T [t/h] = γ [t/m³]· Q [m³/h]. Mechanical power in steady state operation of the considered dump-side conveyor is calculated for different values of input variables, i.e. capacity and speed. Based on achieved results, the parameter estimation scheme presented in [2] has been applied providing the following values of „energy model” coefficients: θ [p.u.] = [0.0036 1.292·10⁵ 0.0312 63.4393]^T. All variables are normalized with base values selected in accordance with rated parameters of motor and the BC, given in the Appendix. Steady state characteristics for $P_{av} = f(v, Q = \text{const})$, given in Fig. 16, are calculated with the estimated parameters $\theta_1, \theta_2, \theta_3$ and θ_4 , for different values of capacity Q (from 0.5 to 1 [p.u.]), by varying speed in the range of $v = [0.4, \dots, 1]$ [p.u.]. For speed values less than 0.4 p.u., the relation (17) is inappropriate, therefore, different functional dependency for $P_{av} = f(v, Q)$ has to be established. Nonetheless, the performed analysis does not apply in this range. Two more characteristics, $P_{av} = f(v, A_{max})$ and $P_{av \min} = f(v, Q)$, are also presented in the same figure. The presented results clearly show that the characteristic for $P_{av \min}$ is to the left of the characteristic $P_{av} = f(v, A_{max})$. Consequently, the considered BC will not be able to operate at speed which provides minimum energy consumption, because it will cause the spillage of material over the belt. Due to this reason, the BC can operate only with speeds equal or higher than the speeds determined by the characteristic $P_{av} = f(v, A_{max})$. Hence, the true minimum of energy consumption will not correspond to the absolute minimum of average mechanical power (P_{av}), but to the average mechanical power, which is determined in accordance with the constraint of maximum capacity.

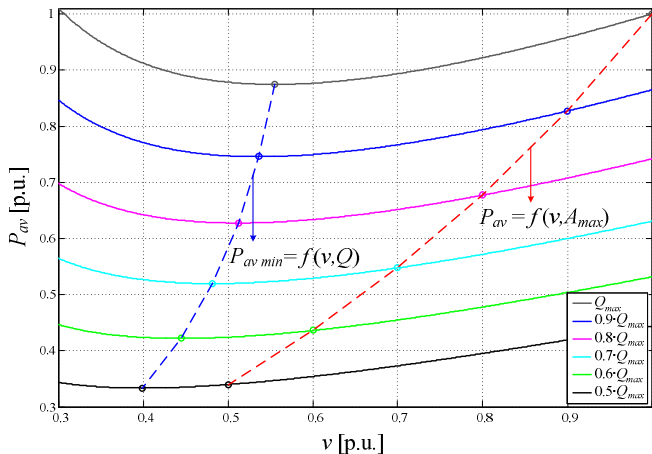

Fig. 16. Characteristics for $P_{av} = f(v, Q = \text{const})$.

Belt conveyors in OPMs always work in the system with excavators and spreaders for the purpose of material handling, so their energy efficiency is affected by many constrains which exist at the equipment or system level. In practice, many belt conveyors are working with reduced capacity, even with empty belts, due to problems which may occur during the system

operation. The paper deals with the optimization problem which is dedicated to optimize the belt conveyor speed under a reduced capacity and under defined system constraints, in order to minimize electrical energy consumption. Hence, the analytical expression for electrical energy consumption is employed as the objective of this problem for minimization. The belt speed is within its defined limits, as well as maximum mass per unit of belt length. They form the constraints of this problem. As additional constraint, the range for time derivative of speed is also introduced. This especially refers to deceleration coefficient which has to fulfill following three criteria, defined in the previous section. Therefore, the optimization problem is formulated as follows,

$$\begin{aligned} \min W_{el}(v_j, Q_j : 1 \leq j \leq N) &= \sum_{j=1}^{j=N} \frac{1}{\eta} P(v_j, Q_j) t_s \\ \text{subject to:} & \\ 0.5 \cdot v_{max} \leq v_j \leq v_{max} & \\ \frac{\Delta v_{min}}{t_s} \leq \frac{v_j - v_{j-1}}{t_s} \leq \frac{\Delta v_{max}}{t_s} & \left. \vphantom{\frac{\Delta v_{min}}{t_s}} \right\} \text{linear constraints} \\ 0 \leq M'_{Lj} \leq M'_{Lmax} & \text{nonlinear constraints} \end{aligned} \quad (19)$$

where η is the overall efficiency of the driving system, t_s is sampling time, $Q_{in} = [Q_{in1}, \dots, Q_{inN}]$ is acquired from file which is recorded on the real system and M'_L [kg/m] = $\gamma \cdot Q_{in} / (3,6 \cdot v)$ is mass of material per unit of belt length. The results of measurements of the implemented algorithm with FLC, which are presented in Fig. 14, are recorded for the same values of input variable Q_{in} . The solution of the optimization problem is the optimum speed $v_{opt} = [v_{opt1}, \dots, v_{optN}]$ for the given value of the input capacity of material, which provides the operation of BC with minimum energy consumption, i.e. with maximum energy efficiency under defined linear and nonlinear constraints. The minimum and maximum speed of the belt, as well as minimum and maximum time derivative of the belt speed present linear constrains, while maximum mass of material per unit of belt length presents nonlinear constraint.

The required solution is obtained by applying the *fmincon* function of MATLAB *Optimization Toolbox* [12], which finds a minimum of a constrained nonlinear multivariable function based on SQP algorithm (sequential quadratic programming).

In the considered case, constants η , $T_{max} = \gamma \cdot Q_{max}$ and M'_{Lmax} are the actual values of the analyzed system of BCs. The lower limit of belt speed is set on 60% of v_r , while the upper limit is set to 100% of v_r . Sampling rate for the input variable Q_{in} is $t_s = 1$ s. Maximum values for acceleration and deceleration coefficients are equal and set to 3.3[%]· v_r/t_s , in accordance with recommendations given in [3]. The result for the optimum speed obtained as the solution of the described optimization problem, v_{opt} , is in excellent agreement with the result of measurement for the fuzzy speed control of BC, v_{ref} , as presented in Fig. 17.

Presented time diagrams also confirm that the variable deceleration in the case of fuzzy speed control does not exceed the maximum value and satisfies all three defined requirements. Therefore, it is proved that the proposed

algorithm with FLC - case B provides operation with minimum energy consumption, in the existing operating conditions and under defined system constraints.

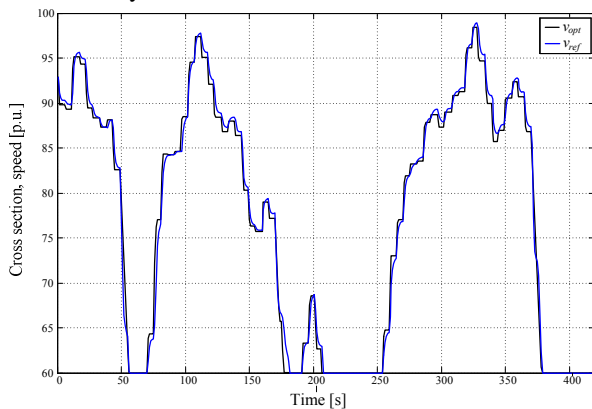

Fig. 17. Reference speed obtained with algorithm with FLC - CASE B, v_{ref} , together with optimum speed obtained with $fmincon$ function, v_{opt} .

IV. CONCLUSION

The paper presents development of the algorithm for generating reference speed of the system of belt conveyors with adjustable speed induction motor drives based on a principle of optimum energy consumption. Three algorithms are presented. Two of them are generating the reference speed based on fuzzy logic control. All of them are tested on the detailed mathematical model of the belt conveyor. The algorithm based on fuzzy logic control which incorporates drive torque as the input variable is implemented on the new belt conveyor system at OPM. The displayed results of energy consumption during eight months of exploitation validate the applied control strategy. It is also confirmed analytically, through a method based on the sequential quadratic programming for finding the minimum of the nonlinear function of multiple variables under given constraints. Considering the indicated advantages of the proposed algorithm, as well as the proven opportunity of its successful implementation, the authors of the paper are expecting that their solution will be applied on similar systems in our country, as well as abroad. They certainly hope that their contribution will reduce the energy consumption and improve the efficiency of the mining process.

APPENDIX

Motor data:

Operating voltage: 690 V;
Winding connection: Δ ;
Power: 1000kW / 995rpm;
Duty: S1, ED 100%;
Efficiency: 96.50%; Power factor: 0.837;
Current: 1036 A; Torque: 9600Nm

BC data:

Belt width 2000mm; Number of drives 4;
Type of drives: frequency converter with DTC;
Maximum length 3.25km; Rated speed 4.65 m/s;
Rated capacity of 6600m³/h

System of BCs data:

Number of belt conveyors: 5;
Total installed power 20 MW;
Current length: 7.5 km..

REFERENCES

- [1] W. Daus, *et al.*, "Raw Coal Loading and Belt Conveyor System at the Nochten Opencast Mine," *Braunkohle Surface Mining*, vol. 50, p. 12, 1998.
- [2] S. Zhang and X. Xia, "Modeling and energy efficiency optimization of belt conveyors," *Applied Energy*, vol. 88, p. 11, 2011.
- [3] Y. Pang and G. Lodewijks, "Improving energy efficiency in material transport systems by fuzzy speed control," in *Logistics and Industrial Informatics (LINDI), 2011 3rd IEEE International Symposium on*, 2011, pp. 159-164.
- [4] B. Jeftenić, *et al.*, "Energy efficiency in transportation of bulk material with frequency controlled drives," in *14th International Power Electronics and Motion Control Conference EPE-PEMC 2010*, Ohrid, Macedonia, 2010, pp. T5 105-113.
- [5] A. G. Tapp, "Energy Saving Troughing Idler Technology," *Bulk solids handling*, vol. 20, pp. 437-449, 2000.
- [6] B. T. Ralf, *et al.*, "Energy efficiency in opencast mine production systems," *Surface Mining - Braunkohle and other Minerals*, vol. 61, p. 8, 2009.
- [7] L. B. Ristić and B. I. Jeftenić, "Implementation of Fuzzy Control to Improve Energy Efficiency of Variable Speed Bulk Material Transportation," *IEEE Transactions on Industrial Electronics*, vol. 59, pp. 2959-2969, 2012.
- [8] B. Jeftenić, *et al.*, "Design and Selection of Belt Conveying Equipment & Systems," in *Design and Selection of Bulk Material Handling Equipment and Systems: Mining, Mineral Processing, Port, Plant and Excavation Engineering*. vol. I, J. Bhattacharya, Ed., I ed Kolkata: Wide Publishing, 2012, p. 254.
- [9] S. S.N., *et al.*, *Introduction to Fuzzy Logic using MATLAB*: Springer, 2007.
- [10] B. Jeftenić, *et al.*, "Optimal Utilization of the Bulk Material Transportation System based on Speed Controlled Drives," in *The XIX International Conference on Electrical Machines ICEM 2010*, Rome, Italy, 2010, pp. 1-6.
- [11] *Fuzzy Controllers- Recent Advances in Theory and Applications*, Sohail Iqbal, Nora Boumella and Juan Carlos Figueroa Garcia ed.: InTech, 2012.
- [12] *Optimization Toolbox User's Guide For Use with MATLAB, Version 2*. Available: www.mathworks.com