

# PI Regulator with Tracking Anti-Windup Based Modified Power Balance Theory for SAPF under Unbalanced Grid Voltage Unbalance Non Linear Loads

Khechiba Kamel, Zellouma Laid, and Benaissa Amar

**Abstract**—This paper presents a modified power balance theory for extracting the reference compensating currents to shunt active power filter (SAPF) which is applied to illuminate current harmonics and compensate reactive power under unbalanced voltages and unbalancing Nonlinear loads. A new method has been proposed based proportional-integrator (PI) controller with tracking anti-windup protection is presented. The power balance theory is used to establish suitable current reference signals. The studied is carried out with Matlab/Simulink and power system tools to verify the performance of the proposed technique. The filtering method of the SAPF can achieve the THD% limit specified by the IEEE-519 standard.

**Index Terms**—Power Balance Theory, STF, SAPF, THD, Tracking Windup, Unbalance grid Voltage, Unbalanced non linear loads

*Original Research Paper*  
DOI: 10.7251/ELS1923075K

## I. INTRODUCTION

Due to growing demand of energy, the power distribution system network becomes more and more polluted due to the presence of power electronic-based converts which creates a non-linear load in house appliances such as a television, computer, printers and fax machines, food preparation and cooking, lighting products that include electronic ballasts, and in industrial applications such as variable speed motor drives for HVAC and converter stations, flexible ac transmission system (FACTS), and static var compensators. Almost all new electrical or electromechanical equipment, contain power electronic circuits and/or systems, these loads increase the burden on the distribution system and pollute the supply system, and the harmonics injected by the power converters becomes inevitable and by consequence influence the performance of

other loads which are connected to the same load terminal [1]. Therefore, it is clearly stated in the harmonic IEEE standard 519 that the total harmonic distortion (THD) for current should be at most 5%. Hence, the 5% of current THD limit has always been the performance target that all researchers and designers are trying their best to achieve. In the beginning, the researchers propose techniques based on the conventional passive filters [2]. And due to its fixed mitigation abilities and bulky size, the designer replaces them. By another filter which uses power semiconductor switching devices such as insulated gate bipolar transistors (IGBT) [3].

Among the solutions proposed and applied by the research to eliminate these harmonics, and minimize the effects of nonlinear is the shunt active power filter (SAPF) [4]. Very much effort has been made to control the SAPF, and different algorithms emerged for the harmonic detection, which considers the speed, the filter stability, easy, inexpensive implementation, and the detection accuracy, in the time domain as well as in frequency domain.

The time domain methods are most widely used based on the instantaneous derivation of reference current signals from harmonic-polluted sources to gain more speed and less complexity in calculations [5]. To generate the reference current for SAPF, the most popular one that has been developed in the field of harmonic detection is the instantaneous power theory by H. Akagi [6]. Which has been proved to be effective operation and has a good performance under balanced voltage source conditions [7]. Among different harmonic compensation techniques, the SRF (Synchronous Reference Frame) method, which is usually used the LPF as a conventional second order low pass filter to separate the DC component of the current [8]. This method leads to an increase in the reaction time of the active power filter by prolonging the time response of the LPF.

One other problem of the conventional SRF technique is that load current compensation will not be well done if the load terminal voltages are distorted, and thus a PLL (Phase Locked Loop) proposed to extract the direct fundamental component of the network voltage [9].

Some papers have proposed different solutions to improve the result of compensation and the drawbacks of the conventional SRF and PQ methods. In [10]. A modified PLL structure was proposed to improve the THD which is limited in the best case

Manuscript received August 12th, 2019. Received in revised form October 14th, 2019. Accepted for publication November 17th, 2019.

Khechiba Kamel, Applied Automation and Industrial Diagnostics Laboratory LAADI, Faculty of Electrical Engineering, University of Djelfa, Algeria (corresponding author to provide phone: +213 671-133-933; e-mail: khechibakamel@gmail.com).

Zellouma Laid, Faculty of Electrical Engineering, University of El oued, Algeria (e-mail: zelloumal3@yahoo.fr)

Benaissa Amar, Faculty of Electrical Engineering, University of Djelfa, Algeria, (e-mail: benaissa\_am@yahoo.fr).

to 2.7%. In [11]. A self-tuning filter was used with SRF and PQ under non-sinusoidal load terminal voltage condition.

This method was limited the THD to 2.30%. In [12]. A 2nd order low pass filter wavelet-based multi-resolution analysis is deployed using SOGI (Second Order Generalized Integrator) to extract the fundamental frequency component of an unbalance and nonlinear load current. The THD of this method is limited to 2.08%. In [13], [14]. Icos $\alpha$  algorithm is used which is consider to be the product of its magnitude and a unity of sine wave which can be obtained from PLL block. The THD gets from this method is limited to 1.25. However, the three-phase power system cannot be continuously balanced, which is the case in the present time, and the reason of this is the majority of loads in the distribution systems are unbalanced in radial distribution feeders, and the power quality problems are more prevailing in the grid which are prime concerns in the distribution system and this necessitates the study of the combined effect of unbalance and nonlinearity on power system voltages and currents. Thus, the direct application of the instantaneous power theory will result in large errors.

To overcome the limitations in the existing methods, a modified power balance theory is proposed and developed in this paper based on cascade second-order filter to handle unbalanced three-phase voltage sources with unbalance load system with practical considerations. The algorithm is simple with less memory requirement which makes it easy to implement and which uses indirect current control technique in estimating the fundamental load components. The DC capacitor voltage is recovered and attains the reference voltage through the PI controller having anti-windup integral action.

## II. LITERATURE REVIEW

The APF technology got a real enhancement and a major factor in advancing the APF technology with the introduction of insulated gate bipolar transistors (IGBTs) [15]. Rather than the use in the initial state the BJTs, MOSFET and GTOs. Based on converter topology, type, and number of phases, the Active Power Filter can be classified Shunt as shown in Fig.1 or Series or a combination of both and can be either a voltage source inverter (VSI) or current source inverter (CSI) in terms of type, the classification can also be in terms of phase a two-wire (single phase) and three- or four-wire three- phase systems.

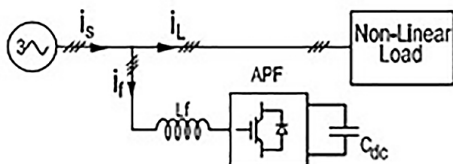

Fig.1. Block diagram of the APF [16]

## III. MATERIAL AND METHODS

The main advantage of power balance theory is the fast detection of distortion with high accuracy and quick response

extraction of reference source currents. The basic equations of power balance theory for the generation of switching signals for VSC are given below.

### A. The in Phase Component of Reference Source Currents

$$V_t = \sqrt{2(V_{sa}^2 + V_{sb}^2 + V_{sc}^2)}/3 \quad (1)$$

$V_t$  is the amplitude of the terminal voltage at PCC. The unity sine waves of the phase main voltages are estimated as:

$$V_{au} = (V_{sa}(t)/V_t), V_{bu} = (V_{sb}(t)/V_t), V_{cu} = (V_{sc}(t)/V_t) \quad (2)$$

The consumed load active power will be calculated as follows:

$$P_L = V_t(i_{la}V_{au} + i_{lb}V_{bu} + i_{lc}V_{cu}) \quad (3)$$

The supply current has two components.

- The first is required for DC component of load consumed power

The magnitude of the fundamental active power component of load current can be estimated as:

$$i_{Ldc} = (2/3) * (P_{Ldc}/V_t) \quad (4)$$

Where  $P_{Ldc}$  is the DC component extracted from the total consumed active power after filter out by using a self-tuning filter (STF) which is the most important part of this control which allows making insensible to the disturbances and filtering correctly the current.

- The second component is required for the self-supporting DC bus voltage of the filter can be expressed as:

$$i_{Ld} = K_p V_{dce} + K_i \int V_{dce} dt \quad (5)$$

Where  $V_{dce} = V_{dc} - V_{dc}^*$  is the error in DC bus voltage between the sensed and the reference respectively. The proposed method is to use the PI controller with anti-windup integral action.

In this paper, study has been carried out using tracking anti-windup scheme.

After we obtain the two parts of the currents, we propose to filter out again to eliminate the ripple by using a second-order low pass filter where the cut-off frequency is 50 Hz and the damping factor Zeta is 0.707.

### B. The Tracking Windup

In nonlinear loads, some effect must be taken into consideration such as the actuator saturation; the neglecting phenomenon leads to closed-loop instability, especially if the process is open-loop unstable.

Such undesirable condition can arise. If the error is too large or it remains non-zero for a long duration during which the integrator causes the rollover [17]. To limit the output a saturation block can be used at the output terminal as shown in Fig. 2.

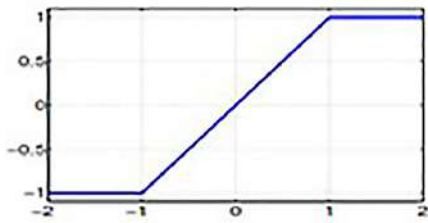

Fig. 2. Saturation function [17]

Saturation can be defined as the static nonlinearity

$$\text{sat}(u) = \begin{cases} U_{\min} & \text{if } U < U_{\min} \\ U & \text{if } -U_{\min} < U < U_{\max} \\ U_{\max} & \text{if } U > U_{\max} \end{cases} \quad (6)$$

$$\text{sat}(u) = \begin{cases} U_{\min} & \text{if } U < U_{\min} \\ U & \text{if } -U_{\min} < U < U_{\max} \\ U_{\max} & \text{if } U > U_{\max} \end{cases} \quad (7)$$

$$\text{sat}(u) = U_{\max} \text{ if } U > U_{\max} \quad (8)$$

Whereas the transfer function of a PI controller is expressed as:

$$G_{PI}(s) = K_p + (K_i/s) \quad (9)$$

The closed-loop transfer function of dc voltage regulation is given by:

$$\begin{aligned} V_{dc}/V_{ref} &= (K_p/C) \\ &\cdot s (K_i/K_p) / [s^2 + (K_p/C)s + (K_i/C)] \end{aligned} \quad (10)$$

We can obtain the proportional constant by solving the second order equation above and replacing the values of the capacitor C, the reference DC voltage which is in our case 120V (simulation parameter Table I) and by knowing  $\zeta 0.707$ ,  $\omega$  and cut off frequency 50Hz respectively.

The choice of limiting gain  $K_S$  in Fig. 3 depends on acceptable restriction on integrator output. The higher value keeps the actual output close to the saturated output which in turn enables the controller to come out of saturation quickly when the error reverses.

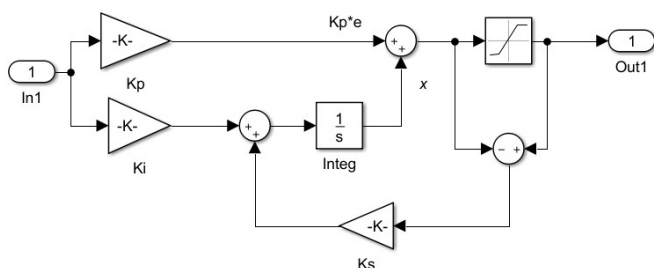

Fig. 3. Block diagram of the Tracking Anti-Windup regulator

Here the difference of actual output and saturated output is fed back through again to reduce the amount of error input error going into the integrator.

From the circuit above

$$U = x + K_p e \quad (11)$$

where:

$$dx/dt = K_i (e - K_S(U - U_{\max})) \quad (12)$$

Hence, by replacing “(11)” into “(12)” yields

$$dx/dt = -K_i K_S x + K_i (1 - K_S K_p) e + K_i K_S U_{\max} \quad (13)$$

The solution of the above equation for a given error  $e(t) = E$  Yields:

$$\begin{aligned} x(t) &= (X_0 - (E/K_S) - U_{\max} + K_p E) \cdot \exp(-k_i k_s t) \\ &+ ((E/K_S) + U_{\max} - K_p e) \end{aligned} \quad (14)$$

Replacing “(14)” in “(11)” yields

$$\begin{aligned} U(t) &= (X_0 - (E/K_S) - U_{\max} + \\ &K_p E) \cdot \exp(-k_i k_s t) \\ &+ ((E/K_S) + U_{\max}) \end{aligned} \quad (15)$$

It can be observed from the dynamic and steady-state relationships that the dynamic part goes to zero if the value of  $K_S$  has to be high and hence  $U(t) \approx U_{\max}$  and controller will come out of saturation quickly when the error input reverses.

### C. Self-Tuning Filter

To obtain a satisfactory extraction, the dynamic regime is slow. In general, the cutoff frequency is chosen between 5 Hz and 35 Hz, which then generates instability of the active power filter during rapid changes in the load.

In the opposite case, if a higher cutoff frequency is chosen, the accuracy of the determination of the alternative component is impaired and may prove insufficient [18]. For these reasons, a new type of extraction filter named self-tuning filter (STF) has been developed as shown in Fig. 4.

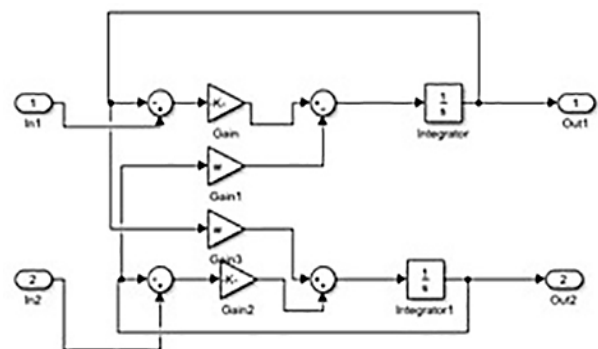

Fig. 4. Block diagram of STF

The transfer function of the STF is defined as:

$$H(s) = V_{xy}(s)/U_{xy}(s) = K \cdot [(s + j\omega)/(s^2 + \omega^2)] \quad (16)$$

From the integral effect on the input magnitude, the STF does not alter the phase of the input, hence  $U_{xy}(s)$  and  $V_{xy}(s)$  have the same phase [19].

The three-phase references of source current are calculated as:

$$i_{ref(a)} = (i_{Ldc} + i_{id})V_{au} \quad (17)$$

$$i_{ref(b)} = (i_{Ldc} + i_{id})V_{bu} \quad (18)$$

$$i_{ref(c)} = (i_{Ldc} + i_{id})V_{cu} \quad (19)$$

The compensating current could be obtained by subtracting the load current from the reference supply current [20]. The generated currents pass through a Hysteresis Current Control HCC to obtain switching signals needed in semiconductors commutation of the VSC.

#### IV. RESULTS AND DISCUSSIONS

A MATLAB/Simulink model of the control system is developed to verify the performance of the proposed technique. Three variable RL type nonlinear load groups' gives in Table I and different operating unbalance supply voltage in Table II.

TABLE I  
SIMULATION PARAMETERS

Parameter	value
Source voltage	100V
System frequency	50Hz
DC link Capacitance	1100 μF
Source inductance	1.3 mH
Source resistance	0.42 Ω
Coupling inductance	2m H
Coupling resistance	0.1 Ω
Load 1	8Ω , 3mH
Load 2	12Ω , 5 mH
Load 3	30Ω , 4 mH
K <sub>p</sub>	0.1074
K <sub>i</sub>	0.2055

TABLE II  
SIMULATION PARAMETERS

	0%	10%	20%	30%
Phase A	100 V	100V	100 V	100 V
Phase B	100 V	90 V	80 V	70 V
Phase C	100 V	110 V	120 V	130 V
THD%	1.115	1.286	1.711	2.411

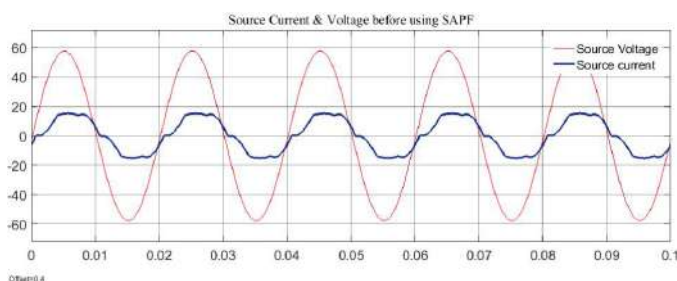

Fig. 5. The system before applying the SAPF (p hase A)

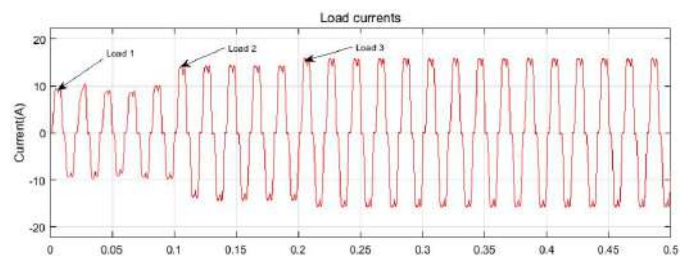

Fig. 6. The load currents

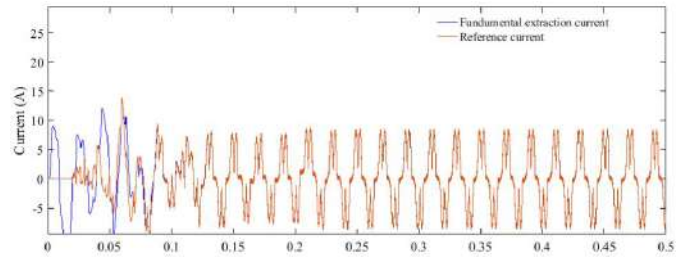

Fig. 7. The reference current followed by the fundamental after using SAPF

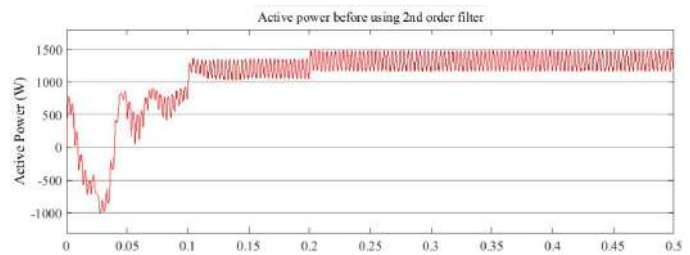

Fig. 8. The fundamental component of the active power of the three phases

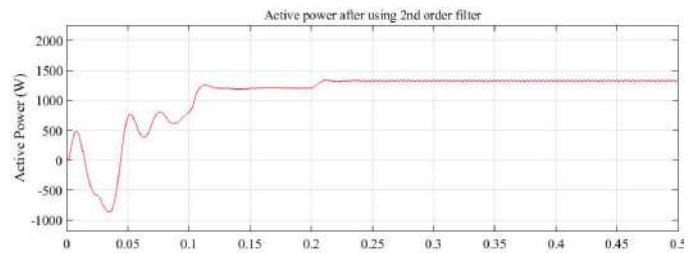

Fig. 9 The fundamental component of the active power of the three phases after using cascade 2<sup>nd</sup> order filters

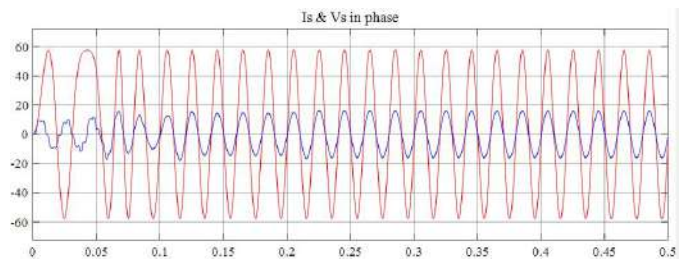

Fig. 10. The system after applying the SAPF (phase A)

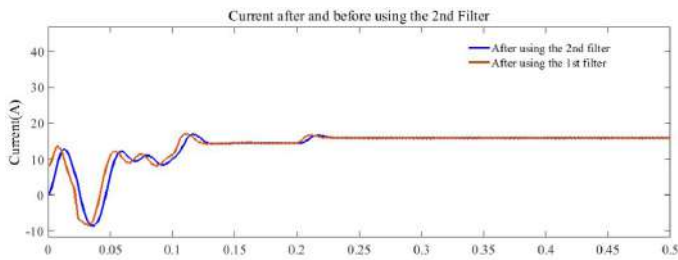

Fig. 11. The DC component of the fundamental current before and after using the 2<sup>nd</sup> order LPF. Stability of the fundamental current after introducing load2 and load 3 at 0.1s, and after 0.2s respectively.

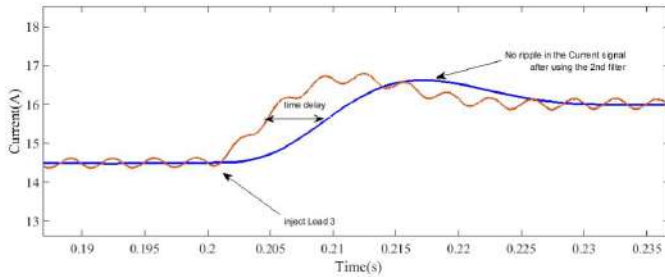

Fig. 12. Elimination of current signal ripple after using 2<sup>nd</sup> cascade filter

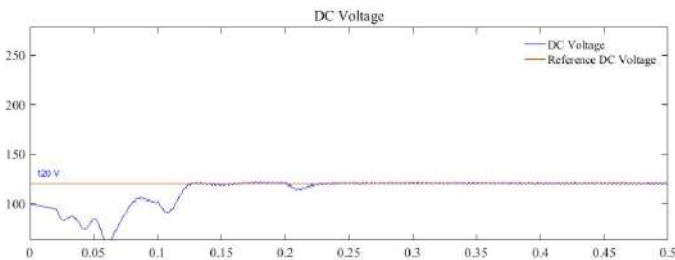

Fig. 13. The Voltage of the DC link side

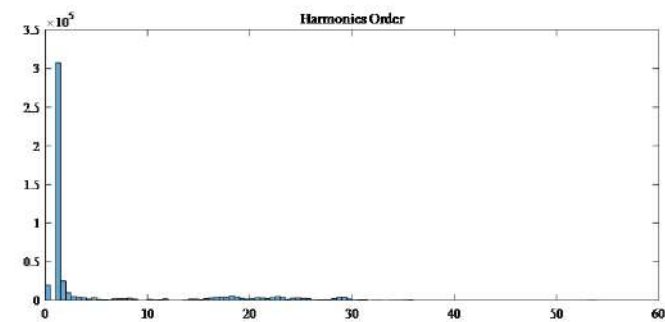

Fig. 14. Harmonic Order

TABLE III  
COMPARISON OF THE PERFORMANCE IN THE PROPOSED METHOD AGAINST OTHER DESIGN

Reference	Technical used	THD %
[10]	modified PLL structure	2.7
[11]	self-tuning filter	2.30
[12]	2nd order low pass filter wavelet-based multiresolution	2.08
[13]-[14]	Icosa	1.25
Presented work	PI controller with Tracking anti windup	1.115

A comparison of the achieved SAPF performance with respect to other realized with various designs for 3 phase unbalance non linear loads is summarized in Table III. It is clear that our proposed shows low percentage of THD even in the case of unbalanced grid voltage.

## V. CONCLUSION

Simulation of three-phase three-wire shunt active power filter under unbalanced nonlinear loads and unbalanced grid voltage have been performed for improving power quality aspect at distribution system such as harmonic suppression. A modified Power Balance Theory technique based on PI controller with Anti windup integral action as a closed-loop regulator to eliminate the roll-over of the integrator and place it within a saturation region have been used to extract the fundamental component of the load current. A combination of a second-order low pass filter with Self Tuning Filter has been utilized for reference to current extraction. The result has shown that the proposed method has been found satisfactory in achieving harmonic reduction, compensation of reactive power and balancing in current supply. The study shows a good performance in terms of THD percentage which gives 1.115% in case of balanced grid voltage unbalanced three nonlinear loads integrated into the system in the different instant of time simulation as shown in Fig. 10 and also by using the proposed solution, the stability of the system on the DC link side is satisfactory. The simulation results from Table II, shows also the standard IEEE 519 is satisfied under 10%, 20%, 30% of unbalanced supply voltage [21].

## REFERENCES

- [1] Singh, B.; Al-Haddad, K.; Chandra, A. "A review of active filters for power quality improvement", *IEEE Trans. Industrial Electronics*, vol.46, no.5, 1999.
- [2] K. Al-Haddad, Power Quality: Problems B. Singh, A. Chandra, *Problems and Mitigation Techniques*, John Wiley and Sons, U.K., 2015, pp. 48–89.
- [3] P. Kanjiya, V. Khadkikar, and H. H. Zeineldin, "A non-iterative optimized algorithm for shunt active power filters under distorted and unbalanced supply voltages" *IEEE Trans. Industrial. Electronics*, vol. 60, no.12, pp.5376–5390, 2013.
- [4] B. Singh, S. Arya, A. Chandra, and K. Al-Haddad, "Implementation of adaptive filter in distribution static compensator", *IEEE Transaction. Industrial Applications*, vol. 50, no. 5, pp. 3026–3036, 2014.
- [5] De AraujoRibeiro, R.L.; De Oliveira Alves Rocha, T.; Maciel de Sousa, R.; dos Santos Junior, E.C.;Lima, A.M.N. "A robust DC-link voltage control strategy to enhance the performance of shunt active power filters without harmonic detection schemes". *IEEE Trans. Industrial. Electron*, vol.62, no. 3, pp. 803–813, 2015.
- [6] M.Ramya, M .Sathyapriya, A. Benazir Hajira ,P.Kumar. "Mitigation of line current harmonics using shunt active filter with instantaneous real and reactive power theory", *Journal of Electrical and Electronics Engineering*. vol. 9, no.2, pp.59–67, Mar-Apr 2014.
- [7] Joao Afonso, Mauricio Aredes, Edson Watanabe, J ulio Martins "Shunt active filter for power quality improvement", In *Proc. Conf. UIE 2000 Electricity for a Sustainable Urban Development*, Lisboa , Porugal, 2000, pp 683-691.
- [8] K-L. Areerak and K-N. Areerak, "The comparison study of harmonic detection methods for shunt active power filters", *International Journal*

- Of Electrical Computer Energetic Electronic and Communication Engineering* vol. 4, no.10, 2010.
- [9] Papan Dey, Saad Mekhilef “Current controllers of active power filter for power quality”, *AUTOMATIKA* vol.56.no.1, pp.42-54, 2015.
- [10] Kesler M, Ozdemir E. “Synchronous reference frame based control method for UPQC under unbalanced and distorted load conditions”. *IEEE Transaction Industrial Electron*, vol.58, no.9, pp. 3967–3975, 2011.
- [11] Biricik S, Ozerdem OC, Redif S, Kmail MOI. “Performance improvement of active power filters based on P-Q and D-Q control methods under non-ideal supply voltage conditions”. In *Proc. Conf Electrical and Electronics Engineering ELECO IEEE*, Bursa, Turkey. New York, NY, USA, 2011, pp. 1312–1316.
- [12] Isaac K, Emmanuel A.F A “2nd order LPF wavelet based control Scheme for shunt active power filter”. In *Proc. Conf. IEEE PES-PowerAfrica*, Accra, Ghana, 2017, pp. 444–448.
- [13] Ilango K ,Manitha P.V, Manjula G Nair “Modifieded *Icos* controller for shunt active filer interfacing renewable energy source and grid” In *Proc. Conf. American Applied Science Research Institute on Power and Energy Systems*, USA, 2012, pp. 62–68.
- [14] Chrls. S , Member, IACSIT , G. Bhuvanewari “ Comparison of three phase shunt active power filter algorithms” *International journal of computers and Electrical Engineering*, vol. 2 no. 1, pp. 1793–8163, February, 2010.
- [15] D. Vrancic. “Design of Anti-Windup and bumpless transfer protection”, Ph.D. dissertation, Dept. Elect. Eng., Ljubljana Univ., Slovenia, 1997,
- [16] Chennai Salim, Benchouia M-T, “Three – phase three wire shunt active power filter based on hysteresis, fuzzy and MLPNN controllers to compensate current harmonics” *Journal of electrical and control engineering American V-king Scientific Publishing*, vol. 3 no. 3, pp. 6–12, 2013.
- [17] A. Visioli. “Modified anti-windup scheme for PID controllers”, *IEE Control Theory and Applications*, *IET Publishing*, vol.150, no.1, pp. 49–54, January 2003.
- [18] Mihai Ciobotaru, Remus Teodorescu and Frede Blaabjerg “A new single-phase PLL structure based on second order generalized integrator”, In *Proc.37<sup>th</sup> Conf. IEEE, Power Electronics Specialists*, South Korea, 2006, pp. 453–459.
- [19] A. Scott Edward Hodel and C. E. Hall. “Variable-structure PID controls to prevent integrator windup”, *IEEE Transactions on Industrial Electronics*, vol.48 no.2, pp. 442–451, 2001.
- [20] J. M. Espi, J. Castello, R. Garcia-Gil, G. Garcera, and E. Figueres, “An adaptive robust predictive current control for three-phase grid connected inverters,” *IEEE Trans. Industrial Electronics*, vol. 58, no. 8, pp. 3537–3546, Aug. 2011.
- [21] *IEEE Recommended Practices and requirement for Harmonic Control on electric power System*, IEEE Standard 519, 1992.